

ON PREMISE
PICTURE BOOK 2021

EFFECTIVE: 1. JANUARY 2021

Riedel
265 YEARS

 **WINE?**

IF YOUR WINE COULD CHOOSE A GLASS, IT WOULD BE RIEDEL.



TABLE OF CONTENT

NEW ITEMS 2021

SL RIEDEL STEMLESS WINGS OP	4-5
RIEDEL FATTO A MANO R.Q.	6-11
RIEDEL MAX RESTAURANT	12-13
RIEDEL WINEWINGS	14-15
SOMMELIERS RESTAURANT	16
RIEDEL VERITAS RESTAURANT	17-19
RIEDEL PERFORMANCE RESTAURANT	20-21
EXTREME RESTAURANT	22-23
RIEDEL RESTAURANT	24-26
VINUM RESTAURANT	28-31
RESTAURANT O	32-35
TUMBLER COLLECTION RESTAURANT	36-39
RIEDEL DRINK SPECIFIC GLASSWARE	40-41
OUVERTURE RESTAURANT	42
MANHATTAN	43
DEGUSTAZIONE	44
SWIRL	45
RIEDEL BAR	46-47
CALIBRATION MARK	48-53
ACCESSOIRES	54
DECANTER MACHINE-MADE	54-55
DECANTER HAND-MADE/1. QUALITY	56-75
LOGO AND POUR AID	76-77
INSTRUCTIONS	78
TRADEMARK	79
TASTING-EVENTS	80
GO GREEN - SUSTAINABILITY	81
CUSTOM MADE	82-83
„SENSORY“ WORK SHOP	84
AGB	85-87

Shipments are subject to our General Terms and Conditions and respective Payment and Delivery Terms. We do not accept only delivery Terms and Conditions and respective Payment and Delivery Terms. Our General Terms and Conditions and respective Payment and Delivery Terms may be viewed by means of display and notice board in our business offices and can be submitted on request. You are accepting these General Terms and Conditions and respective Payment and Delivery Terms when the contract is concluded.

We regret any errors in our specifications for sizes, colours, volumes or prices. However, claims resulting from such errors cannot be accepted.



0789/0

SL RIEDEL STEMMLES WINGS OP
CABERNET SAUVIGNON



0789/07

SL RIEDEL STEMMLES WINGS OP
PINOT NOIR/
NEBBIOLO



0789/15

SL RIEDEL STEMMLES WINGS OP
RIESLING/
CHAMPAGNE GLASS

ITEM	fine crystal machine-made		fine crystal machine-made		fine crystal machine-made	
	Item no.:	0789/0	Item no.:	0789/07	Item no.:	0789/15
	Height/glass:	121 mm	Height/glass:	121 mm	Height/glass:	109 mm
	Capacity/glass:	670 ccm	Capacity/glass:	620 ccm	Capacity/glass:	420 ccm
	Design:	2021	Design:	2021	Design:	2021
PACKAGING	Pieces/Bill unit:	1	Pieces/Bill unit:	1	Pieces/Bill unit:	1
TYPE AND QUANTITY	Bill units/MP:	12	Bill units/MP:	12	Bill units/MP:	12
MASTERPACK	Length:	421 mm	Length:	421 mm	Length:	382 mm
DIMENSIONS	Width:	312 mm	Width:	312 mm	Width:	282 mm
	Height:	1226 mm	Height:	1226 mm	Height:	114 mm
	Weight:	1800 gr	Weight:	1800 gr	Weight:	2964 gr
EURO PALLET	MP/pallet:	84	MP/pallet:	84	MP/pallet:	128
	MP/layer:	6	MP/layer:	6	MP/layer:	8
	Layer/pallet:	14	Layer/pallet:	14	Layer/pallet:	16
CONTAINER PALLET	MP/pallet:	153	MP/pallet:	153	MP/pallet:	209
HIGH CUBE	MP/layer:	9	MP/layer:	9	MP/layer:	11
	Layer/pallet:	17	Layer/pallet:	17	Layer/pallet:	19

EAN
BILL UNIT





RIEDEL
FATTO A MANO





GLASSES

RQ
FATTO A MANO
by Riedel

RIEDEL FATTO A MANO



4905/00BWT
BORDEAUX
GRAND CRU RQ



4905/16BWT
BURGUNDY
GRAND CRU RQ



4905/08BWT
CABERNET/
MERLOT RQ



4905/41BWT
SYRAH RQ



4905/07BWT
PINOT NOIR RQ

ITEM	fine crystal hand-made Item no.: 4905/00BWT		fine crystal hand-made Item no.: 4905/16BWT		fine crystal hand-made Item no.: 4905/08BWT		fine crystal hand-made Item no.: 4905/41BWT		fine crystal hand-made Item no.: 4905/07BWT	
	Height/glass:	250 mm	Height/glass:	250 mm	Height/glass:	250 mm	Height/glass:	250 mm	Height/glass:	250 mm
	Capacity/glass:	860 ccm	Capacity/glass:	1050 ccm	Capacity/glass:	625 ccm	Capacity/glass:	600 ccm	Capacity/glass:	705 ccm
	Design:	2017	Design:	2017	Design:	2017	Design:	2017	Design:	2017
PACKAGING	Pieces/Bill unit:	1	Pieces/Bill unit:	1	Pieces/Bill unit:	1	Pieces/Bill unit:	1	Pieces/Bill unit:	1
TYPE AND QUANTITY	Bill units/MP:	4	Bill units/MP:	4	Bill units/MP:	6	Bill units/MP:	6	Bill units/MP:	6
MASTERPACK	Length:	235 mm	Length:	322 mm	Length:	331 mm	Length:	331 mm	Length:	331 mm
DIMENSIONS	Width:	235 mm	Width:	228 mm	Width:	226 mm	Width:	226 mm	Width:	226 mm
	Height:	295 mm	Height:	289 mm	Height:	290 mm	Height:	290 mm	Height:	290 mm
	Weight:	840 gr	Weight:	1001 gr	Weight:	1262 gr	Weight:	1232 gr	Weight:	1262 gr
EURO PALLET	MP/pallet:	90	MP/pallet:	72	MP/pallet:	66	MP/pallet:	66	MP/pallet:	66
	MP/layer:	15	MP/layer:	12	MP/layer:	11	MP/layer:	11	MP/layer:	11
	Layer/pallet:	6	Layer/pallet:	6	Layer/pallet:	6	Layer/pallet:	6	Layer/pallet:	6
CONTAINER PALLET	MP/pallet:	140	MP/pallet:	128	MP/pallet:	128	MP/pallet:	128	MP/pallet:	128
HIGH CUBE	MP/layer:	20	MP/layer:	16	MP/layer:	16	MP/layer:	16	MP/layer:	16
	Layer/pallet:	7	Layer/pallet:	8	Layer/pallet:	8	Layer/pallet:	8	Layer/pallet:	8
EAN BILL UNIT										

ORDER OF R.Q. WILL ONLY BE CONFIRMED WHEN AVAILABLE



4905/28BWT
CHAMPAGNE
WINEGLASS RQ



4905/15BWT
RIESLING/
ZINFANDEL RQ



4905/97BWT
OAKED
CHARDONNAY RQ

ITEM	fine crystal hand-made Item no.: 4905/28BWT		fine crystal hand-made Item no.: 4905/15BWT		fine crystal hand-made Item no.: 4905/97BWT	
	Height/glass:	250 mm	Height/glass:	250 mm	Height/glass:	250 mm
	Capacity/glass:	445 ccm	Capacity/glass:	395 ccm	Capacity/glass:	620 ccm
	Design:	2017	Design:	2017	Design:	2017
PACKAGING TYPE AND QUANTITY	Pieces/Bill unit:	1	Pieces/Bill unit:	1	Pieces/Bill unit:	1
	Bill units/MP:	6	Bill units/MP:	6	Bill units/MP:	6
MASTERPACK DIMENSIONS	Length:	331 mm	Length:	331 mm	Length:	331 mm
	Width:	226 mm	Width:	226 mm	Width:	226 mm
	Height:	290 mm	Height:	290 mm	Height:	290 mm
	Weight:	1232 gr	Weight:	1082 gr	Weight:	1232 gr
EURO PALLET	MP/pallet:	66	MP/pallet:	66	MP/pallet:	66
	MP/layer:	11	MP/layer:	11	MP/layer:	11
	Layer/pallet:	6	Layer/pallet:	6	Layer/pallet:	6
CONTAINER PALLET HIGH CUBE	MP/pallet:	128	MP/pallet:	128	MP/pallet:	128
	MP/layer:	16	MP/layer:	16	MP/layer:	16
	Layer/pallet:	8	Layer/pallet:	8	Layer/pallet:	8
EAN BILL UNIT	 9 006206 816866		 9 006206 816811		 9 006206 817108	



GLASSES

RIEDEL FATTO A MANO



4905/07P
PINOT NOIR RQ



4905/0P
CABERNET RQ



4905/41P
SYRAH RQ



4905/28P
CHAMPAGNE
WINE GLASS RQ



4905/15P
RIESLING/
ZINFANDEL RQ

ITEM	fine crystal hand-made		fine crystal hand-made		fine crystal hand-made		fine crystal hand-made		fine crystal hand-made	
	Item no.:	4905/07P	Item no.:	4905/0P	Item no.:	4905/41P	Item no.:	4905/28P	Item no.:	4905/15P
	Height/glass:	250 mm	Height/glass:	250 mm	Height/glass:	250 mm	Height/glass:	250 mm	Height/glass:	250 mm
	Capacity/glass:	705 ccm	Capacity/glass:	625 ccm	Capacity/glass:	600 ccm	Capacity/glass:	445 ccm	Capacity/glass:	395 ccm
	Design:	2017	Design:	2017	Design:	2017	Design:	2017	Design:	2017
PACKAGING TYPE AND QUANTITY	Pieces/Bill unit:	1	Pieces/Bill unit:	1	Pieces/Bill unit:	1	Pieces/Bill unit:	1	Pieces/Bill unit:	1
	Bill units/MP:	6	Bill units/MP:	6	Bill units/MP:	6	Bill units/MP:	6	Bill units/MP:	6
MASTERPACK DIMENSIONS	Length:	331 mm	Length:	331 mm	Length:	331 mm	Length:	331 mm	Length:	331 mm
	Width:	226 mm	Width:	226 mm	Width:	226 mm	Width:	226 mm	Width:	226 mm
	Height:	290 mm	Height:	290 mm	Height:	290 mm	Height:	290 mm	Height:	290 mm
	Weight:	1262 gr	Weight:	1262 gr	Weight:	1232 gr	Weight:	1232 gr	Weight:	1082 gr
EURO PALLET	MP/pallet:	66	MP/pallet:	66	MP/pallet:	66	MP/pallet:	66	MP/pallet:	66
	MP/layer:	11	MP/layer:	11	MP/layer:	11	MP/layer:	11	MP/layer:	11
	Layer/pallet:	6	Layer/pallet:	6	Layer/pallet:	6	Layer/pallet:	6	Layer/pallet:	6
CONTAINER PALLET HIGH CUBE	MP/pallet:	128	MP/pallet:	128	MP/pallet:	128	MP/pallet:	128	MP/pallet:	128
	MP/layer:	16	MP/layer:	16	MP/layer:	16	MP/layer:	16	MP/layer:	16
	Layer/pallet:	8	Layer/pallet:	8	Layer/pallet:	8	Layer/pallet:	8	Layer/pallet:	8

EAN BILL UNIT





4905/97P
OAKED
CHARDONNAY RQ

ITEM	fine crystal	
	hand-made	
	Item no.:	4905/97P
	Height/glass:	250 mm
	Capacity/glass:	620 ccm
	Design:	2017

PACKAGING TYPE AND QUANTITY	Pieces/Bill unit:	1
	Bill units/MP:	6

MASTERPACK DIMENSIONS	Length:	331 mm
	Width:	226 mm
	Height:	290 mm
	Weight:	1232 gr

EURO PALLET	MP/pallet:	66
	MP/layer:	11
	Layer/pallet:	6

CONTAINER PALLET HIGH CUBE	MP/pallet:	128
	MP/layer:	16
	Layer/pallet:	8

EAN
BILL UNIT



BILL UNIT
4905/XX

**ORDER OF R.Q. WILL ONLY
BE CONFIRMED WHEN AVAILABLE**

RIEDEL MAX RESTAURANT



0423/0
CABERNET



0423/28
CHAMPAGNE GLASS



0423/15
RIESLING

ITEM	fine crystal machine-made		fine crystal machine-made		fine crystal machine-made	
	Item no.:	0423/0	Item no.:	0423/28	Item no.:	0423/15
	Height/glass:	300 mm	Height/glass:	300 mm	Height/glass:	300 mm
	Capacity/glass:	820 ccm	Capacity/glass:	320 ccm	Capacity/glass:	490 ccm
	Design:	2020	Design:	2020	Design:	2020
PACKAGING TYPE AND QUANTITY	Pieces/Bill unit:	1	Pieces/Bill unit:	1	Pieces/Bill unit:	1
	Bill units/MP:	6	Bill units/MP:	6	Bill units/MP:	6
MASTERPACK DIMENSIONS	Length:	362 mm	Length:	362 mm	Length:	362 mm
	Width:	241 mm	Width:	241 mm	Width:	241 mm
	Height:	353 mm	Height:	353 mm	Height:	353 mm
	Weight:	1561 gr	Weight:	1491 gr	Weight:	1491 gr
EURO PALLET	MP/pallet:	45	MP/pallet:	60	MP/pallet:	60
	MP/layer:	9	MP/layer:	12	MP/layer:	12
	Layer/pallet:	5	Layer/pallet:	5	Layer/pallet:	5
CONTAINER PALLET HIGH CUBE	MP/pallet:	96	MP/pallet:	96	MP/pallet:	96
	MP/layer:	16	MP/layer:	16	MP/layer:	16
	Layer/pallet:	6	Layer/pallet:	6	Layer/pallet:	6

EAN
BILL UNIT





RIEDEL WINEWINGS RESTAURANT



0123/0
CABERNET
SAUVIGNON



0123/07
PINOT NOIR/
NEBBIOLO







0123/41
SYRAH





0123/28
CHAMPAGNE WINE



0123/15
RIESLING

ITEM	fine crystal machine-made		fine crystal machine-made		fine crystal machine-made		fine crystal machine-made		fine crystal machine-made	
	Item no.:	0123/0	Item no.:	0123/07	Item no.:	0123/41	Item no.:	0123/28	Item no.:	0123/15
	Height/glass:	250 mm	Height/glass:	250 mm	Height/glass:	250 mm	Height/glass:	250 mm	Height/glass:	250 mm
	Capacity/glass:	1002 ccm	Capacity/glass:	950 ccm	Capacity/glass:	865 ccm	Capacity/glass:	742 ccm	Capacity/glass:	1017 ccm
	Design:	2020	Design:	2020	Design:	2020	Design:	2020	Design:	2020
PACKAGING	Pieces/Bill unit:	1	Pieces/Bill unit:	1	Pieces/Bill unit:	1	Pieces/Bill unit:	1	Pieces/Bill unit:	1
TYPE AND QUANTITY	Bill units/MP:	6	Bill units/MP:	6	Bill units/MP:	6	Bill units/MP:	6	Bill units/MP:	6
MASTERPACK	Length:	342 mm	Length:	342 mm	Length:	342 mm	Length:	342 mm	Length:	342 mm
DIMENSIONS	Width:	230 mm	Width:	230 mm	Width:	230 mm	Width:	230 mm	Width:	230 mm
	Height:	264 mm	Height:	264 mm	Height:	264 mm	Height:	264 mm	Height:	264 mm
	Weight:	1432 gr	Weight:	1456 gr	Weight:	1442 gr	Weight:	1370 gr	Weight:	1450 gr
EURO PALLET	MP/pallet:	63	MP/pallet:	63	MP/pallet:	70	MP/pallet:	70	MP/pallet:	63
	MP/layer:	9	MP/layer:	9	MP/layer:	10	MP/layer:	10	MP/layer:	9
	Layer/pallet:	7	Layer/pallet:	7	Layer/pallet:	7	Layer/pallet:	7	Layer/pallet:	7
CONTAINER PALLET	MP/pallet:	96	MP/pallet:	96	MP/pallet:	120	MP/pallet:	120	MP/pallet:	96
HIGH CUBE	MP/layer:	12	MP/layer:	12	MP/layer:	15	MP/layer:	15	MP/layer:	12
	Layer/pallet:	8	Layer/pallet:	8	Layer/pallet:	8	Layer/pallet:	8	Layer/pallet:	8
EAN										
BILL UNIT	9 006206 531363		9 006206 531370		9 006206 531417		9 006206 531394		9 006206 531387	





ITEM	fine crystal machine-made		fine crystal machine-made	
	Item no.:	0123/33	Item no.:	0123/97
	Height/glass:	250 mm	Height/glass:	250 mm
	Capacity/glass:	742 ccm	Capacity/glass:	736 ccm
	Design:	2020	Design:	2020
PACKAGING	Pieces/Bill unit:	1	Pieces/Bill unit:	1
TYPE AND QUANTITY	Bill units/MP:	6	Bill units/MP:	6
MASTERPACK	Length:	342 mm	Length:	342 mm
DIMENSIONS	Width:	230 mm	Width:	230 mm
	Height:	264 mm	Height:	264 mm
	Weight:	1370 gr	Weight:	1358 gr
EURO PALLET	MP/pallet:	70	MP/pallet:	70
	MP/layer:	10	MP/layer:	10
	Layer/pallet:	7	Layer/pallet:	7
CONTAINER PALLET	MP/pallet:	120	MP/pallet:	120
HIGH CUBE	MP/layer:	15	MP/layer:	15
	Layer/pallet:	8	Layer/pallet:	8
EAN				
BILL UNIT	9 006206 531400		9 006206 531424	



0300/00
BORDEAUX
GRAND CRU



0300/16
BURGUNDY
GRAND CRU

ITEM	fine crystal machine-made		fine crystal machine-made	
	Item no.:	0300/00	Item no.:	0300/16
	Height/glass:	270 mm	Height/glass:	248 mm
	Capacity/glass:	860 ccm	Capacity/glass:	1050 ccm
	Design:	2013	Design:	2013
PACKAGING	Pieces/Bill unit:	1	Pieces/Bill unit:	1
TYPE AND QUANTITY	Bill units/MP:	6	Bill units/MP:	6
MASTERPACK	Length:	337 mm	Length:	367 mm
DIMENSIONS	Width:	227 mm	Width:	247 mm
	Height:	293 mm	Height:	270 mm
	Weight:	1680 gr	Weight:	1740 gr
EURO PALLET	MP/pallet:	66	MP/pallet:	63
	MP/layer:	11	MP/layer:	9
	Layer/pallet:	6	Layer/pallet:	7
CONTAINER PALLET	MP/pallet:	105	MP/pallet:	96
HIGH CUBE	MP/layer:	15	MP/layer:	12
	Layer/pallet:	7	Layer/pallet:	8
EAN				
BILL UNIT	9 006206 521104		9 006206 521111	



0449/30
NEW WORLD
SHIRAZ



0449/0
CABERNET/
MERLOT



0449/07
OLD WORLD
PINOT NOIR



0449/41
OLD WORLD
SYRAH



0449/67
NEW WORLD PINOT NOIR/
NEBBIOLO/
ROSÉ CHAMPAGNE

ITEM	fine crystal machine-made		fine crystal machine-made		fine crystal machine-made		fine crystal machine-made		fine crystal machine-made	
	Item no.:		Item no.:		Item no.:		Item no.:		Item no.:	
	0449/30		0449/0		0449/07		0449/41		0449/67	
	Height/glass:	246 mm	Height/glass:	235 mm	Height/glass:	235 mm	Height/glass:	235 mm	Height/glass:	235 mm
	Capacity/glass:	650 ccm	Capacity/glass:	625 ccm	Capacity/glass:	705 ccm	Capacity/glass:	600 ccm	Capacity/glass:	800 ccm
	Design:	2014	Design:	2014	Design:	2014	Design:	2014	Design:	2014
PACKAGING TYPE AND QUANTITY	Pieces/Bill unit:	1	Pieces/Bill unit:	1	Pieces/Bill unit:	1	Pieces/Bill unit:	1	Pieces/Bill unit:	1
	Bill units/MP:	6	Bill units/MP:	6	Bill units/MP:	6	Bill units/MP:	6	Bill units/MP:	6
MASTERPACK DIMENSIONS	Length:	305 mm	Length:	305 mm	Length:	342 mm	Length:	305 mm	Length:	342 mm
	Width:	206 mm	Width:	206 mm	Width:	230 mm	Width:	206 mm	Width:	230 mm
	Height:	277 mm	Height:	264 mm	Height:	265 mm	Height:	264 mm	Height:	265 mm
	Weight:	1240 gr	Weight:	1177 gr	Weight:	1274 gr	Weight:	1226 gr	Weight:	1351 gr
EURO PALLET	MP/pallet:	72	MP/pallet:	84	MP/pallet:	70	MP/pallet:	84	MP/pallet:	70
	MP/layer:	12	MP/layer:	12	MP/layer:	10	MP/layer:	12	MP/layer:	10
	Layer/pallet:	6	Layer/pallet:	7	Layer/pallet:	7	Layer/pallet:	7	Layer/pallet:	7
CONTAINER PALLET HIGH CUBE	MP/pallet:	160	MP/pallet:	160	MP/pallet:	120	MP/pallet:	160	MP/pallet:	120
	MP/layer:	20	MP/layer:	20	MP/layer:	15	MP/layer:	20	MP/layer:	15
	Layer/pallet:	8	Layer/pallet:	8	Layer/pallet:	8	Layer/pallet:	8	Layer/pallet:	8
EAN BILL UNIT										
	9 006206 523289		9 006206 523207		9 006206 523290		9 006206 523276		9 006206 523283	



0449/28
CHAMPAGNE
WINE GLASS



0449/15
RIESLING/
ZINFANDEL



0449/33
SAUVIGNON
BLANC







0449/05
VIOGNIER/
CHARDONNAY



0449/97
OAKED
CHARDONNAY

ITEM	fine crystal machine-made		fine crystal machine-made		fine crystal machine-made		fine crystal machine-made		fine crystal machine-made	
	Item no.:		Item no.:		Item no.:		Item no.:		Item no.:	
	0449/28		0449/15		0449/33		0449/05		0449/97	
	Height/glass:	235 mm	Height/glass:	235 mm	Height/glass:	235 mm	Height/glass:	225 mm	Height/glass:	217 mm
	Capacity/glass:	445 ccm	Capacity/glass:	395 ccm	Capacity/glass:	440 ccm	Capacity/glass:	370 ccm	Capacity/glass:	620 ccm
	Design:	2014	Design:	2014	Design:	2017	Design:	2014	Design:	2014
PACKAGING	Pieces/Bill unit:	1	Pieces/Bill unit:	1	Pieces/Bill unit:	1	Pieces/Bill unit:	1	Pieces/Bill unit:	1
TYPE AND QUANTITY	Bill units/MP:	6	Bill units/MP:	6	Bill units/MP:	6	Bill units/MP:	6	Bill units/MP:	6
MASTERPACK	Length:	277 mm	Length:	263 mm	Length:	277 mm	Length:	264 mm	Length:	338 mm
DIMENSIONS	Width:	186 mm	Width:	176 mm	Width:	186 mm	Width:	183 mm	Width:	229 mm
	Height:	265 mm	Height:	265 mm	Height:	265 mm	Height:	255 mm	Height:	245 mm
	Weight:	1089 gr	Weight:	1063 gr	Weight:	1029 gr	Weight:	1042 gr	Weight:	1224 gr
EURO PALLET	MP/pallet:	112	MP/pallet:	133	MP/pallet:	112	MP/pallet:	133	MP/pallet:	77
	MP/layer:	16	MP/layer:	19	MP/layer:	16	MP/layer:	19	MP/layer:	11
	Layer/pallet:	7	Layer/pallet:	7	Layer/pallet:	7	Layer/pallet:	7	Layer/pallet:	7
CONTAINER PALLET	MP/pallet:	184	MP/pallet:	208	MP/pallet:	184	MP/pallet:	225	MP/pallet:	135
HIGH CUBE	MP/layer:	23	MP/layer:	26	MP/layer:	23	MP/layer:	25	MP/layer:	15
	Layer/pallet:	8	Layer/pallet:	8	Layer/pallet:	8	Layer/pallet:	9	Layer/pallet:	9
EAN										
BILL UNIT	9 006206 523252		9 006206 523245		9 006206 526055		9 006206 523214		9 006206 523290	



ITEM	fine crystal machine-made		fine crystal machine-made		fine crystal machine-made		fine crystal machine-made	
	Item no.:		Item no.:		Item no.:		Item no.:	
	0449/09		0449/71		0449/11		0449/02	
	Height/glass:	170 mm	Height/glass:	235 mm	Height/glass:	160 mm	Height/glass:	145 mm
	Capacity/glass:	240 ccm	Capacity/glass:	152 ccm	Capacity/glass:	435 ccm	Capacity/glass:	415 ccm
	Design:	2014	Design:	2016	Design:	2016	Design:	2019
PACKAGING	Pieces/Bill unit:	1	Pieces/Bill unit:	1	Pieces/Bill unit:	1	Pieces/Bill unit:	1
TYPE AND QUANTITY	Bill units/MP:	6	Bill units/MP:	6	Bill units/MP:	6	Bill units/MP:	6
MASTERPACK	Length:	336 mm	Length:	265 mm	Length:	274 mm	Length:	274 mm
DIMENSIONS	Width:	225 mm	Width:	179 mm	Width:	184 mm	Width:	184 mm
	Height:	199 mm	Height:	263 mm	Height:	186 mm	Height:	174 mm
	Weight:	1020 gr	Weight:	957 gr	Weight:	954 gr	Weight:	893 gr
EURO PALLET	MP/pallet:	99	MP/pallet:	133	MP/pallet:	170	MP/pallet:	187
	MP/layer:	11	MP/layer:	19	MP/layer:	17	MP/layer:	17
	Layer/pallet:	9	Layer/pallet:	7	Layer/pallet:	10	Layer/pallet:	11
CONTAINER PALLET	MP/pallet:	165	MP/pallet:	208	MP/pallet:	276	MP/pallet:	299
HIGH CUBE	MP/layer:	15	MP/layer:	26	MP/layer:	23	MP/layer:	23
	Layer/pallet:	11	Layer/pallet:	8	Layer/pallet:	12	Layer/pallet:	13
EAN								
BILL UNIT	9 006206 522859		9 006206 525355		9 006206 525331		9 006206 530847	

RIEDEL PERFORMANCE RESTAURANT



0884/0
CABERNET/
MERLOT



0884/67
PINOT NOIR







0884/41
SYRAH/
SHIRAZ



0884/28
CHAMPAGNE
GLASS



0884/33
SAUVIGNON
BLANC

ITEM	fine crystal machine-made		fine crystal machine-made		fine crystal machine-made		fine crystal machine-made		fine crystal machine-made	
	Item no.:	0884/0	Item no.:	0884/67	Item no.:	0884/41	Item no.:	0884/28	Item no.:	0884/33
	Height/glass:	245 mm	Height/glass:	245 mm	Height/glass:	245 mm	Height/glass:	245 mm	Height/glass:	245 mm
	Capacity/glass:	834 ccm	Capacity/glass:	830 ccm	Capacity/glass:	631 ccm	Capacity/glass:	375 ccm	Capacity/glass:	440 ccm
	Design:	2018	Design:	2018	Design:	2018	Design:	2018	Design:	2019
PACKAGING	Pieces/Bill unit:	1	Pieces/Bill unit:	1	Pieces/Bill unit:	1	Pieces/Bill unit:	1	Pieces/Bill unit:	1
TYPE AND QUANTITY	Bill units/MP:	6	Bill units/MP:	6	Bill units/MP:	6	Bill units/MP:	6	Bill units/MP:	6
MASTERPACK DIMENSIONS	Length:	334 mm	Length:	344 mm	Length:	319 mm	Length:	289 mm	Length:	289 mm
	Width:	224 mm	Width:	231 mm	Width:	215 mm	Width:	194 mm	Width:	194 mm
	Height:	268 mm	Height:	267 mm	Height:	267 mm	Height:	267 mm	Height:	267 mm
	Weight:	1235 gr	Weight:	1303 gr	Weight:	1181 gr	Weight:	1082 gr	Weight:	1112 gr
EURO PALLET	MP/pallet:	77	MP/pallet:	70	MP/pallet:	84	MP/pallet:	112	MP/pallet:	112
	MP/layer:	11	MP/layer:	10	MP/layer:	12	MP/layer:	16	MP/layer:	16
	Layer/pallet:	7	Layer/pallet:	7	Layer/pallet:	7	Layer/pallet:	7	Layer/pallet:	7
CONTAINER PALLET HIGH CUBE	MP/pallet:	120	MP/pallet:	120	MP/pallet:	144	MP/pallet:	176	MP/pallet:	176
	MP/layer:	15	MP/layer:	15	MP/layer:	18	MP/layer:	22	MP/layer:	22
	Layer/pallet:	8	Layer/pallet:	8	Layer/pallet:	8	Layer/pallet:	8	Layer/pallet:	8
EAN BILL UNIT										
	9 006206 527564		9 006206 527540		9 006206 527595		9 006206 527557		9 006206 529414	



RIEDEL PERFORMANCE RESTAURANT MOVIE

performance
— RESTAURANT —



0884/15
RIESLING



0884/97
CHARDONNAY

ITEM	fine crystal machine-made		fine crystal machine-made	
	Item no.:		Item no.:	
	0884/15		0884/97	
	Height/glass:	245 mm	Height/glass:	245 mm
	Capacity/glass:	623 ccm	Capacity/glass:	727 mm
	Design:	2018	Design:	2018
PACKAGING	Pieces/Bill unit:	1	Pieces/Bill unit:	1
TYPE AND QUANTITY	Bill units/MP:	6	Bill units/MP:	6
MASTERPACK	Length:	319 mm	Length:	344 mm
DIMENSIONS	Width:	215 mm	Width:	231 mm
	Height:	267 mm	Height:	267 mm
	Weight:	1181 gr	Weight:	1303 gr
EURO PALLET	MP/pallet:	84	MP/pallet:	70
	MP/layer:	12	MP/layer:	10
	Layer/pallet:	7	Layer/pallet:	7
CONTAINER PALLET	MP/pallet:	144	MP/pallet:	120
HIGH CUBE	MP/layer:	18	MP/layer:	15
	Layer/pallet:	8	Layer/pallet:	8
EAN				
BILL UNIT	9 006206 527533		9 006206 527588	



OPTIC IMPACT

Performance's unique optic impact not only adds a pleasing visual aspect to the bowl, but also increases the inner surface area, allowing the wine to open up and to fully show every aroma and subtle nuance.



EXTREME RESTAURANT



0454/0
CABERNET



0454/07
PINOT NOIR/
NEBBIOLO



0454/32
SHIRAZ



0454/05
RIESLING/
SAUVIGNON BLANC



0454/55
ROSÉ/CHAMPAGNE
GLASS

ITEM	fine crystal machine-made		fine crystal machine-made		fine crystal machine-made		fine crystal machine-made		fine crystal machine-made	
	Item no.:	0454/0	Item no.:	0454/07	Item no.:	0454/32	Item no.:	0454/05	Item no.:	0454/55
	Height/glass:	247 mm	Height/glass:	243 mm	Height/glass:	244 mm	Height/glass:	240 mm	Height/glass:	230 mm
	Capacity/glass:	800 ccm	Capacity/glass:	770 ccm	Capacity/glass:	709 ccm	Capacity/glass:	460 ccm	Capacity/glass:	322 ccm
	Design:	2017	Design:	2017	Design:	2017	Design:	2017	Design:	2017
PACKAGING	Pieces/Bill unit:	1	Pieces/Bill unit:	1	Pieces/Bill unit:	1	Pieces/Bill unit:	1	Pieces/Bill unit:	1
TYPE AND QUANTITY	Bill units/MP:	12	Bill units/MP:	12	Bill units/MP:	12	Bill units/MP:	12	Bill units/MP:	12
MASTERPACK DIMENSIONS	Length:	443 mm	Length:	479 mm	Length:	443 mm	Length:	371 mm	Length:	371 mm
	Width:	330 mm	Width:	357 mm	Width:	330 mm	Width:	276 mm	Width:	276 mm
	Height:	261 mm	Height:	257 mm	Height:	261 mm	Height:	254 mm	Height:	254 mm
	Weight:	2986 gr	Weight:	3131 gr	Weight:	2822 gr	Weight:	2458 gr	Weight:	2269 gr
EURO PALLET	MP/pallet:	35	MP/pallet:	28	MP/pallet:	35	MP/pallet:	56	MP/pallet:	56
	MP/layer:	5	MP/layer:	4	MP/layer:	5	MP/layer:	8	MP/layer:	8
	Layer/pallet:	7	Layer/pallet:	7	Layer/pallet:	7	Layer/pallet:	7	Layer/pallet:	7
CONTAINER PALLET HIGH CUBE	MP/pallet:	64	MP/pallet:	54	MP/pallet:	64	MP/pallet:	99	MP/pallet:	99
	MP/layer:	8	MP/layer:	6	MP/layer:	8	MP/layer:	11	MP/layer:	11
	Layer/pallet:	8	Layer/pallet:	9	Layer/pallet:	8	Layer/pallet:	9	Layer/pallet:	9
EAN BILL UNIT										
	9 006206 513000		9 006206 513024		9 006206 312689		9 006206 513017		9 006206 524105	





0454/97
OAKED
CHARDONNAY



0454/85
PROSECCO
SUPERIORE



0454/17
COCKTAIL

ITEM	fine crystal machine-made		fine crystal machine-made		fine crystal machine-made	
	Item no.:	0454/97	Item no.:	0454/85	Item no.:	0454/17
	Height/glass:	227 mm	Height/glass:	222 mm	Height/glass:	175 mm
	Capacity/glass:	670 ccm	Capacity/glass:	305 ccm	Capacity/glass:	250 ccm
	Design:	2017	Design:	2017	Design:	2017
PACKAGING	Pieces/Bill unit:	1	Pieces/Bill unit:	1	Pieces/Bill unit:	1
TYPE AND QUANTITY	Bill units/MP:	12	Bill units/MP:	12	Bill units/MP:	12
MASTERPACK	Length:	479 mm	Length:	371 mm	Length:	479 mm
DIMENSIONS	Width:	357 mm	Width:	276 mm	Width:	357 mm
	Height:	251 mm	Height:	254 mm	Height:	257 mm
	Weight:	2950 gr	Weight:	2265 gr	Weight:	2957 gr
EURO PALLET	MP/pallet:	28	MP/pallet:	56	MP/pallet:	28
	MP/layer:	4	MP/layer:	8	MP/layer:	4
	Layer/pallet:	7	Layer/pallet:	7	Layer/pallet:	7
CONTAINER PALLET	MP/pallet:	54	MP/pallet:	99	MP/pallet:	54
HIGH CUBE	MP/layer:	6	MP/layer:	11	MP/layer:	6
	Layer/pallet:	9	Layer/pallet:	9	Layer/pallet:	9
EAN						
BILL UNIT	9 006206 513031		9 006206 524112		9 006206 513048	



MASTERPACK
0454/XX



0447/00
BORDEAUX
GRAND CRU



0447/30
OLD WORLD
SYRAH







0447/07
NEW WORLD
PINOT NOIR



0446/30
SYRAH



0446/0
CABERNET/
MERLOT

ITEM	fine crystal machine-made		fine crystal machine-made		fine crystal machine-made		fine crystal machine-made		fine crystal machine-made	
	Item no.:		Item no.:		Item no.:		Item no.:		Item no.:	
	0447/00		0447/30		0447/07		0446/30		0446/0	
	Height/glass:	255 mm	Height/glass:	237 mm	Height/glass:	229 mm	Height/glass:	226 mm	Height/glass:	217 mm
	Capacity/glass:	960 ccm	Capacity/glass:	640 ccm	Capacity/glass:	850 ccm	Capacity/glass:	650 ccm	Capacity/glass:	610 ccm
	Design:	2010	Design:	2010	Design:	2010	Design:	2002	Design:	2001
PACKAGING	Pieces/Bill unit:	1	Pieces/Bill unit:	1	Pieces/Bill unit:	1	Pieces/Bill unit:	1	Pieces/Bill unit:	1
TYPE AND QUANTITY	Bill units/MP:	12	Bill units/MP:	12	Bill units/MP:	12	Bill units/MP:	12	Bill units/MP:	12
MASTERPACK DIMENSIONS	Length:	455 mm	Length:	410 mm	Length:	444 mm	Length:	444 mm	Length:	444 mm
	Width:	339 mm	Width:	306 mm	Width:	332 mm	Width:	332 mm	Width:	332 mm
	Height:	270 mm	Height:	252 mm	Height:	243 mm	Height:	243 mm	Height:	243 mm
	Weight:	3117 gr	Weight:	3005 gr	Weight:	2600 gr	Weight:	2552 gr	Weight:	2642 gr
EURO PALLET	MP/pallet:	35	MP/pallet:	42	MP/pallet:	35	MP/pallet:	35	MP/pallet:	35
	MP/layer:	5	MP/layer:	6	MP/layer:	5	MP/layer:	5	MP/layer:	5
	Layer/pallet:	7	Layer/pallet:	7	Layer/pallet:	7	Layer/pallet:	7	Layer/pallet:	7
CONTAINER PALLET HIGH CUBE	MP/pallet:	56	MP/pallet:	81	MP/pallet:	72	MP/pallet:	72	MP/pallet:	72
	MP/layer:	7	MP/layer:	9	MP/layer:	8	MP/layer:	8	MP/layer:	8
	Layer/pallet:	8	Layer/pallet:	9	Layer/pallet:	9	Layer/pallet:	9	Layer/pallet:	9
EAN BILL UNIT										
	9 006206 515936		9 006206 515851		9 006206 513956		9 006206 511775		9 006206 511761	

RIEDEL

—RESTAURANT—



0446/07
PINOT NOIR



0446/15
ZINFANDEL



0446/48
CHAMPAGNE
GLASS



0446/15
RIESLING



0446/58
CHAMPAGNE
WINE GLASS

ITEM	fine crystal machine-made Item no.: 0446/07		fine crystal machine-made Item no.: 0446/15		fine crystal machine-made Item no.: 0446/48		fine crystal machine-made Item no.: 0446/15		fine crystal machine-made Item no.: 0446/58	
	Height/glass:	215 mm	Height/glass:	214 mm	Height/glass:	217 mm	Height/glass:	214 mm	Height/glass:	221 mm
	Capacity/glass:	700 ccm	Capacity/glass:	370 ccm	Capacity/glass:	260 ccm	Capacity/glass:	370 ccm	Capacity/glass:	440 ccm
	Design:	2001	Design:	2002	Design:	2001	Design:	2002	Design:	2018
PACKAGING TYPE AND QUANTITY	Pieces/Bill unit:	1	Pieces/Bill unit:	1	Pieces/Bill unit:	1	Pieces/Bill unit:	1	Pieces/Bill unit:	1
	Bill units/MP:	12	Bill units/MP:	12	Bill units/MP:	12	Bill units/MP:	12	Bill units/MP:	12
MASTERPACK DIMENSIONS	Length:	444 mm	Length:	368 mm	Length:	295 mm	Length:	368 mm	Length:	367 mm
	Width:	332 mm	Width:	275 mm	Width:	219 mm	Width:	275 mm	Width:	271 mm
	Height:	243 mm	Height:	244 mm	Height:	232 mm	Height:	244 mm	Height:	230 mm
	Weight:	2614 gr	Weight:	2130 gr	Weight:	1865 gr	Weight:	2130 gr	Weight:	2304 gr
EURO PALLET	MP/pallet:	35	MP/pallet:	56	MP/pallet:	104	MP/pallet:	56	MP/pallet:	64
	MP/layer:	5	MP/layer:	8	MP/layer:	13	MP/layer:	8	MP/layer:	8
	Layer/pallet:	7	Layer/pallet:	7	Layer/pallet:	8	Layer/pallet:	7	Layer/pallet:	8
CONTAINER PALLET HIGH CUBE	MP/pallet:	72	MP/pallet:	99	MP/pallet:	180	MP/pallet:	99	MP/pallet:	110
	MP/layer:	8	MP/layer:	11	MP/layer:	18	MP/layer:	11	MP/layer:	11
	Layer/pallet:	9	Layer/pallet:	9	Layer/pallet:	10	Layer/pallet:	9	Layer/pallet:	10
EAN BILL UNIT										
	9 006206 511747		9 006206 511730		9 006206 511945		9 006206 511730		9 006206 527335	



MASTERPACK
0446/0

RIEDEL RESTAURANT





0446/05
CHARDONNAY/
VIOGNIER



0446/97
OAKED
CHARDONNAY



0446/02
WATER

ITEM	fine crystal machine-made		fine crystal machine-made		fine crystal machine-made	
	Item no.:	0446/05	Item no.:	0446/97	Item no.:	0446/02
	Height/glass:	203 mm	Height/glass:	197 mm	Height/glass:	145 mm
	Capacity/glass:	350 ccm	Capacity/glass:	700 ccm	Capacity/glass:	350 ccm
	Design:	2001	Design:	2001	Design:	2001
PACKAGING	Pieces/Bill unit:	1	Pieces/Bill unit:	1	Pieces/Bill unit:	1
TYPE AND QUANTITY	Bill units/MP:	12	Bill units/MP:	12	Bill units/MP:	12
MASTERPACK	Length:	368 mm	Length:	444 mm	Length:	341 mm
DIMENSIONS	Width:	275 mm	Width:	332 mm	Width:	257 mm
	Height:	244 mm	Height:	243 mm	Height:	174 mm
	Weight:	2102 gr	Weight:	2695 gr	Weight:	1819 gr
EURO PALLET	MP/pallet:	56	MP/pallet:	35	MP/pallet:	110
	MP/layer:	8	MP/layer:	5	MP/layer:	10
	Layer/pallet:	7	Layer/pallet:	7	Layer/pallet:	11
CONTAINER PALLET	MP/pallet:	99	MP/pallet:	72	MP/pallet:	182
HIGH CUBE	MP/layer:	11	MP/layer:	8	MP/layer:	14
	Layer/pallet:	9	Layer/pallet:	9	Layer/pallet:	13
EAN						
BILL UNIT	9 006206 511723		9 006206 511754		9 006206 511938	



VINUM
RESTAURANT







0416/30-6
SYRAH/
SHIRAZ



0416/0-6
CABERNET SAUVIGNON/
MERLOT







0416/07-6
PINOT NOIR



0416/15-6
ZINFANDEL



0416/15-6
RIESLING
GRAND CRU

ITEM	fine crystal machine-made Item no.: 0416/30-6		fine crystal machine-made Item no.: 0416/0-6		fine crystal machine-made Item no.: 0416/07-6		fine crystal machine-made Item no.: 0416/15-6		fine crystal machine-made Item no.: 0416/15-6	
	Height/glass:	236 mm	Height/glass:	225 mm	Height/glass:	210 mm	Height/glass:	210 mm	Height/glass:	210 mm
	Capacity/glass:	700 ccm	Capacity/glass:	610 ccm	Capacity/glass:	700 ccm	Capacity/glass:	400 ccm	Capacity/glass:	400 ccm
	Design:	1995	Design:	1986	Design:	1986	Design:	1992	Design:	1992
PACKAGING	Pieces/Bill unit:	1	Pieces/Bill unit:	1	Pieces/Bill unit:	1	Pieces/Bill unit:	1	Pieces/Bill unit:	1
TYPE AND QUANTITY	Bill units/MP:	6	Bill units/MP:	6	Bill units/MP:	6	Bill units/MP:	6	Bill units/MP:	6
MASTERPACK DIMENSIONS	Length:	305 mm	Length:	305 mm	Length:	342 mm	Length:	256 mm	Length:	256 mm
	Width:	205 mm	Width:	205 mm	Width:	231 mm	Width:	174 mm	Width:	174 mm
	Height:	261 mm	Height:	255 mm	Height:	241 mm	Height:	242 mm	Height:	242 mm
	Weight:	1328 gr	Weight:	1271 gr	Weight:	1347 gr	Weight:	1089 gr	Weight:	1089 gr
EURO PALLET	MP/pallet:	84	MP/pallet:	84	MP/pallet:	70	MP/pallet:	140	MP/pallet:	140
	MP/layer:	12	MP/layer:	12	MP/layer:	10	MP/layer:	20	MP/layer:	20
	Layer/pallet:	7	Layer/pallet:	7	Layer/pallet:	7	Layer/pallet:	7	Layer/pallet:	7
CONTAINER PALLET HIGH CUBE	MP/pallet:	160	MP/pallet:	180	MP/pallet:	135	MP/pallet:	252	MP/pallet:	252
	MP/layer:	20	MP/layer:	20	MP/layer:	15	MP/layer:	28	MP/layer:	28
	Layer/pallet:	8	Layer/pallet:	9	Layer/pallet:	9	Layer/pallet:	9	Layer/pallet:	9
EAN BILL UNIT	 9 006206 510030		 9 006206 510016		 9 006206 510023		 9 006206 510047		 9 006206 510047	





0416/05-6
VIOGNIER/
CHARDONNAY



0416/58-6
CHAMPAGNE
WINE GLASS



0416/48-6
CUVÉE
PRESTIGE

ITEM	fine crystal machine-made Item no.: 0416/05-6		fine crystal machine-made Item no.: 0416/48-6		fine crystal machine-made Item no.: 0416/48-6	
	Height/glass:	198 mm	Height/glass:	225 mm	Height/glass:	218 mm
	Capacity/glass:	350 ccm	Capacity/glass:	445 ccm	Capacity/glass:	230 ccm
	Design:	1986	Design:	2018	Design:	1999
PACKAGING	Pieces/Bill unit:	1	Pieces/Bill unit:	1	Pieces/Bill unit:	1
TYPE AND QUANTITY	Bill units/MP:	6	Bill units/MP:	6	Bill units/MP:	6
MASTERPACK	Length:	260 mm	Length:	277 mm	Length:	227 mm
DIMENSIONS	Width:	175 mm	Width:	185 mm	Width:	154 mm
	Height:	228 mm	Height:	241 mm	Height:	248 mm
	Weight:	1044 gr	Weight:	1275 gr	Weight:	959 gr
EURO PALLET	MP/pallet:	152	MP/pallet:	112	MP/pallet:	175
	MP/layer:	19	MP/layer:	16	MP/layer:	25
	Layer/pallet:	8	Layer/pallet:	7	Layer/pallet:	7
CONTAINER PALLET	MP/pallet:	280	MP/pallet:	207	MP/pallet:	324
HIGH CUBE	MP/layer:	28	MP/layer:	23	MP/layer:	36
	Layer/pallet:	10	Layer/pallet:	9	Layer/pallet:	9
EAN						
BILL UNIT	9 006206 510054		9 006206 527526		9 006206 510122	



BILL UNIT
0416/XX-6



0412/30
SYRAH/
SHIRAZ



0412/0
CABERNET/
MERLOT



0412/07
PINOT/
NEBBIOLO



0412/28
CHAMPAGNE
GLASS



0412/15
RIESLING/
SAUVIGNON BLANC

ITEM	fine crystal machine-made		fine crystal machine-made		fine crystal machine-made		fine crystal machine-made		fine crystal machine-made	
	Item no.:	0412/30	Item no.:	0412/0	Item no.:	0412/07	Item no.:	0412/28	Item no.:	0412/15
	Height/glass:	132 mm	Height/glass:	121 mm	Height/glass:	110 mm	Height/glass:	122 mm	Height/glass:	108 mm
	Capacity/glass:	620 ccm	Capacity/glass:	600 ccm	Capacity/glass:	690 ccm	Capacity/glass:	264 ccm	Capacity/glass:	375 ccm
	Design:	2003	Design:	2003	Design:	2003	Design:	2014	Design:	2003
PACKAGING	Pieces/Bill unit:	1	Pieces/Bill unit:	1	Pieces/Bill unit:	1	Pieces/Bill unit:	1	Pieces/Bill unit:	1
TYPE AND QUANTITY	Bill units/MP:	12	Bill units/MP:	12	Bill units/MP:	12	Bill units/MP:	12	Bill units/MP:	12
MASTERPACK DIMENSIONS	Length:	404 mm	Length:	404 mm	Length:	356 mm	Length:	267 mm	Length:	340 mm
	Width:	308 mm	Width:	308 mm	Width:	265 mm	Width:	202 mm	Width:	260 mm
	Height:	151 mm	Height:	140 mm	Height:	245 mm	Height:	135 mm	Height:	127 mm
	Weight:	1787 gr	Weight:	1770 gr	Weight:	2149 gr	Weight:	1322 gr	Weight:	1679 gr
EURO PALLET	MP/pallet:	72	MP/pallet:	78	MP/pallet:	63	MP/pallet:	210	MP/pallet:	160
	MP/layer:	6	MP/layer:	6	MP/layer:	9	MP/layer:	15	MP/layer:	10
	Layer/pallet:	12	Layer/pallet:	13	Layer/pallet:	7	Layer/pallet:	14	Layer/pallet:	16
CONTAINER PALLET HIGH CUBE	MP/pallet:	135	MP/pallet:	144	MP/pallet:	117	MP/pallet:	408	MP/pallet:	280
	MP/layer:	9	MP/layer:	9	MP/layer:	13	MP/layer:	24	MP/layer:	14
	Layer/pallet:	15	Layer/pallet:	16	Layer/pallet:	9	Layer/pallet:	17	Layer/pallet:	20
EAN BILL UNIT										
	9 006206 512225		9 006206 512232		9 006206 512249		9 006206 522354		9 006206 512270	



0412/05
VIOGNIER/
CHARDONNAY



0412/97
OAKED
CHARDONNAY



0412/60
SPIRITS



0412/67
PINOT NOIR

ITEM	fine crystal machine-made		fine crystal machine-made		fine crystal machine-made		fine crystal machine-made	
	Item no.:	0412/05	Item no.:	0412/97	Item no.:	0412/60	Item no.:	0412/67
	Height/glass:	96 mm	Height/glass:	94 mm	Height/glass:	90 mm	Height/glass:	124 mm
	Capacity/glass:	320 ccm	Capacity/glass:	580 ccm	Capacity/glass:	235 ccm	Capacity/glass:	762 ccm
	Design:	2003	Design:	2003	Design:	2004	Design:	2014
PACKAGING	Pieces/Bill unit:	1	Pieces/Bill unit:	1	Pieces/Bill unit:	1	Pieces/Bill unit:	1
TYPE AND QUANTITY	Bill units/MP:	12	Bill units/MP:	12	Bill units/MP:	12	Bill units/MP:	12
MASTERPACK	Length:	340 mm	Length:	356 mm	Length:	300 mm	Length:	475 mm
DIMENSIONS	Width:	260 mm	Width:	232 mm	Width:	230 mm	Width:	354 mm
	Height:	115 mm	Height:	245 mm	Height:	108 mm	Height:	133 mm
	Weight:	1457 gr	Weight:	1844 gr	Weight:	1299 gr	Weight:	1932 gr
EURO PALLET	MP/pallet:	160	MP/pallet:	77	MP/pallet:	221	MP/pallet:	56
	MP/layer:	10	MP/layer:	11	MP/layer:	13	MP/layer:	4
	Layer/pallet:	16	Layer/pallet:	7	Layer/pallet:	17	Layer/pallet:	14
CONTAINER PALLET	MP/pallet:	280	MP/pallet:	135	MP/pallet:	378	MP/pallet:	119
HIGH CUBE	MP/layer:	14	MP/layer:	15	MP/layer:	18	MP/layer:	7
	Layer/pallet:	20	Layer/pallet:	9	Layer/pallet:	21	Layer/pallet:	17
EAN								
BILL UNIT	9 006206 512263		9 006206 512266		9 006206 512591		9 006206 522583	



0412/05R
HAPPY O







0412/05G
HAPPY O



0412/05Y
HAPPY O



0412/05B
HAPPY O

ITEM	fine crystal machine-made		fine crystal machine-made		fine crystal machine-made		fine crystal machine-made	
	Item no.:	0412/05-R	Item no.:	0412/05-G	Item no.:	0412/05-Y	Item no.:	0412/05-B
	Height/glass:	96 mm	Height/glass:	96 mm	Height/glass:	96 mm	Height/glass:	96 mm
	Capacity/glass:	320 ccm	Capacity/glass:	320 ccm	Capacity/glass:	320 ccm	Capacity/glass:	320 ccm
	Design:	2014	Design:	2014	Design:	2014	Design:	2014
PACKAGING	Pieces/Bill unit:	1	Pieces/Bill unit:	1	Pieces/Bill unit:	1	Pieces/Bill unit:	1
TYPE AND QUANTITY	Bill units/MP:	12	Bill units/MP:	12	Bill units/MP:	12	Bill units/MP:	12
MASTERPACK DIMENSIONS	Length:	340 mm	Length:	340 mm	Length:	340 mm	Length:	340 mm
	Width:	260 mm	Width:	260 mm	Width:	260 mm	Width:	260 mm
	Height:	115 mm	Height:	115 mm	Height:	115 mm	Height:	115 mm
	Weight:	1457 gr	Weight:	1457 gr	Weight:	1457 gr	Weight:	1457 gr
EURO PALLET	MP/pallet:	160	MP/pallet:	160	MP/pallet:	160	MP/pallet:	160
	MP/layer:	10	MP/layer:	10	MP/layer:	10	MP/layer:	10
	Layer/pallet:	16	Layer/pallet:	16	Layer/pallet:	16	Layer/pallet:	16
CONTAINER PALLET HIGH CUBE	MP/pallet:	280	MP/pallet:	280	MP/pallet:	280	MP/pallet:	280
	MP/layer:	14	MP/layer:	14	MP/layer:	14	MP/layer:	14
	Layer/pallet:	20	Layer/pallet:	20	Layer/pallet:	20	Layer/pallet:	20
EAN BILL UNIT	 9 006206 523498		 9 006206 523474		 9 006206 523481		 9 006206 523504	



0412/05V
HAPPY O







0412/05C
HAPPY O



0412/05O
HAPPY O



0412/05A
HAPPY O

ITEM	fine crystal machine-made		fine crystal machine-made		fine crystal machine-made		fine crystal machine-made	
	Item no.:	0412/05V	Item no.:	0412/05C	Item no.:	0412/05O	Item no.:	0412/05A
	Height/glass:	96 mm	Height/glass:	96 mm	Height/glass:	96 mm	Height/glass:	96 mm
	Capacity/glass:	320 ccm	Capacity/glass:	320 ccm	Capacity/glass:	320 ccm	Capacity/glass:	320 ccm
	Design:	2014	Design:	2014	Design:	2014	Design:	2014
PACKAGING	Pieces/Bill unit:	1	Pieces/Bill unit:	1	Pieces/Bill unit:	1	Pieces/Bill unit:	1
TYPE AND QUANTITY	Bill units/MP:	12	Bill units/MP:	12	Bill units/MP:	12	Bill units/MP:	12
MASTERPACK	Length:	340 mm	Length:	340 mm	Length:	340 mm	Length:	340 mm
DIMENSIONS	Width:	260 mm	Width:	260 mm	Width:	260 mm	Width:	260 mm
	Height:	115 mm	Height:	115 mm	Height:	115 mm	Height:	115 mm
	Weight:	1457 gr	Weight:	1457 gr	Weight:	1457 gr	Weight:	1457 gr
EURO PALLET	MP/pallet:	160	MP/pallet:	160	MP/pallet:	160	MP/pallet:	160
	MP/layer:	10	MP/layer:	10	MP/layer:	10	MP/layer:	10
	Layer/pallet:	16	Layer/pallet:	16	Layer/pallet:	16	Layer/pallet:	16
CONTAINER PALLET	MP/pallet:	280	MP/pallet:	280	MP/pallet:	280	MP/pallet:	280
HIGH CUBE	MP/layer:	14	MP/layer:	14	MP/layer:	14	MP/layer:	14
	Layer/pallet:	20	Layer/pallet:	20	Layer/pallet:	20	Layer/pallet:	20
EAN								
BILL UNIT	9 006206 525942		9 006206 525928		9 006206 525935		9 006206 525911	



BILL UNIT
0412/0

TUMBLER COLLECTION RESTAURANT



0512/05
OPTICAL O
WHISKY



0512/90
OPTICAL O
LONGDRINK



0418/02
SPEY
WHISKY



0418/04
SPEY
LONGDRINK

ITEM	fine crystal machine-made		fine crystal machine-made		fine crystal machine-made		fine crystal machine-made	
	Item no.:	0512/05	Item no.:	0512/90	Item no.:	0418/02	Item no.:	0418/04
	Height/glass:	96 mm	Height/glass:	113 mm	Height/glass:	102 mm	Height/glass:	148 mm
	Capacity/glass:	344 ccm	Capacity/glass:	580 ccm	Capacity/glass:	295 ccm	Capacity/glass:	375 ccm
	Design:	2018	Design:	2018	Design:	2018	Design:	2018
PACKAGING TYPE AND QUANTITY	Pieces/Bill unit:	1	Pieces/Bill unit:	1	Pieces/Bill unit:	1	Pieces/Bill unit:	1
	Bill units/MP:	12	Bill units/MP:	12	Bill units/MP:	12	Bill units/MP:	12
MASTERPACK DIMENSIONS	Length:	340 mm	Length:	404 mm	Length:	398 mm	Length:	350 mm
	Width:	260 mm	Width:	308 mm	Width:	296 mm	Width:	267 mm
	Height:	115 mm	Height:	140 mm	Height:	133 mm	Height:	190 mm
	Weight:	1673 gr	Weight:	2034 gr	Weight:	5302 gr	Weight:	6516 gr
EURO PALLET	MP/pallet:	160	MP/pallet:	78	MP/pallet:	56	MP/pallet:	64
	MP/layer:	10	MP/layer:	6	MP/layer:	8	MP/layer:	8
	Layer/pallet:	16	Layer/pallet:	13	Layer/pallet:	7	Layer/pallet:	8
CONTAINER PALLET HIGH CUBE	MP/pallet:	280	MP/pallet:	144	MP/pallet:	110	MP/pallet:	84
	MP/layer:	14	MP/layer:	9	MP/layer:	10	MP/layer:	14
	Layer/pallet:	20	Layer/pallet:	16	Layer/pallet:	11	Layer/pallet:	6

EAN
BILL UNIT



MASTERPACK
XX/XX



0512/02 S1
RIEDEL FIRE
WHISKY







0512/04 S1
RIEDEL FIRE
LONGDRINK



0512/20 S1
RIEDEL FIRE
ALL PURPOSE GLASS



0512/04 S2
LOUIS LONGDRINK
©KYLE SOLÁ PRODUCT DESIGN

ITEM	fine crystal machine-made Item no.: 0512/02 S1		fine crystal machine-made Item no.: 0512/04 S1		fine crystal machine-made Item no.: 0512/20 S1		fine crystal machine-made Item no.: 0512/04 S2	
	Height/glass:	98 mm	Height/glass:	151 mm	Height/glass:	151 mm	Height/glass:	154 mm
	Capacity/glass:	295 ccm	Capacity/glass:	375 ccm	Capacity/glass:	355 ccm	Capacity/glass:	375 ccm
	Design:	2018	Design:	2018	Design:	2020	Design:	2018
PACKAGING	Pieces/Bill unit:	1	Pieces/Bill unit:	1	Pieces/Bill unit:	1	Pieces/Bill unit:	1
TYPE AND QUANTITY	Bill units/MP:	12	Bill units/MP:	12	Bill units/MP:	12	Bill units/MP:	12
MASTERPACK DIMENSIONS	Length:	398 mm	Length:	350 mm	Length:	391 mm	Length:	350 mm
	Width:	296 mm	Width:	267 mm	Width:	297 mm	Width:	267 mm
	Height:	133 mm	Height:	190 mm	Height:	185 mm	Height:	190 mm
	Weight:	4102 gr	Weight:	5684 gr	Weight:	4934 gr	Weight:	5384 gr
EURO PALLET	MP/pallet:	112	MP/pallet:	80	MP/pallet:	80	MP/pallet:	80
	MP/layer:	8	MP/layer:	8	MP/layer:	8	MP/layer:	8
	Layer/pallet:	14	Layer/pallet:	10	Layer/pallet:	10	Layer/pallet:	10
CONTAINER PALLET HIGH CUBE	MP/pallet:	140	MP/pallet:	91	MP/pallet:	110	MP/pallet:	104
	MP/layer:	10	MP/layer:	13	MP/layer:	10	MP/layer:	13
	Layer/pallet:	14	Layer/pallet:	7	Layer/pallet:	11	Layer/pallet:	8
EAN BILL UNIT	 9 006206 527472		 9 006206 527502		 9 006206 531257		 9 006206 527519	

TUMBLER COLLECTION RESTAURANT





0512/02 S5
RIEDEL SHADOWS
TUMBLER



0512/67
ALL PURPOSE GLASS



0512/23 S1
FIRE PITCHER

ITEM	fine crystal machine-made		fine crystal machine-made		fine crystal machine-made	
	Item no.:	0512/02 S5	Item no.:	0512/67	Item no.:	0512/23 S1
	Height/glass:	102 mm	Height/glass:	124 mm	Height/glass:	205 mm
	Capacity/glass:	323 ccm	Capacity/glass:	762 ccm	Capacity/glass:	1040 ccm
	Design:	2019	Design:	2019	Design:	2019
PACKAGING	Pieces/Bill unit:	1	Pieces/Bill unit:	1	Pieces/Bill unit:	1
TYPE AND QUANTITY	Bill units/MP:	12	Bill units/MP:	12	Bill units/MP:	4
MASTERPACK	Length:	354 mm	Length:	475 mm	Length:	560 mm
DIMENSIONS	Width:	265 mm	Width:	354 mm	Width:	167 mm
	Height:	124 mm	Height:	133 mm	Height:	254 mm
	Weight:	4731 gr	Weight:	1932 gr	Weight:	5647 gr
EURO PALLET	MP/pallet:	81	MP/pallet:	56	MP/pallet:	63
	MP/layer:	9	MP/layer:	4	MP/layer:	9
	Layer/pallet:	9	Layer/pallet:	24	Layer/pallet:	7
CONTAINER PALLET	MP/pallet:	117	MP/pallet:	229	MP/pallet:	91
HIGH CUBE	MP/layer:	13	MP/layer:	7	MP/layer:	13
	Layer/pallet:	9	Layer/pallet:	17	Layer/pallet:	7
EAN						
BILL UNIT	9 006206 530137		9 006206 530052		9 006206 529971	

TUMBLER COLLECTION RESTAURANT



0512/02B
RIEDEL FIRE
WHISKY COLOUR
BLUE







0512/02R
RIEDEL FIRE
WHISKY COLOUR
RED



0512/02Y
RIEDEL FIRE
WHISKY COLOUR
YELLOW



0512/02G
RIEDEL FIRE
WHISKY COLOUR
GREEN

ITEM	fine crystal machine-made		fine crystal machine-made		fine crystal machine-made		fine crystal machine-made	
	Item no.:	0512/02B	Item no.:	0512/02R	Item no.:	0512/02Y	Item no.:	0512/02G
	Height/glass:	98 mm	Height/glass:	98 mm	Height/glass:	98 mm	Height/glass:	98 mm
	Capacity/glass:	295 cmm	Capacity/glass:	295 cmm	Capacity/glass:	295 cmm	Capacity/glass:	295 cmm
	Design:	2019	Design:	2019	Design:	2019	Design:	2019
PACKAGING	Pieces/Bill unit:	1	Pieces/Bill unit:	1	Pieces/Bill unit:	1	Pieces/Bill unit:	1
TYPE AND QUANTITY	Bill units/MP:	12	Bill units/MP:	12	Bill units/MP:	12	Bill units/MP:	12
MASTERPACK	Length:	398 mm	Length:	398 mm	Length:	398 mm	Length:	398 mm
DIMENSIONS	Width:	296 mm	Width:	296 mm	Width:	296 mm	Width:	296 mm
	Height:	133 mm	Height:	133 mm	Height:	133 mm	Height:	133 mm
	Weight:	4102 gr	Weight:	4102 gr	Weight:	4102 gr	Weight:	4102 gr
EURO PALLET	MP/pallet:	112	MP/pallet:	112	MP/pallet:	112	MP/pallet:	112
	MP/layer:	8	MP/layer:	8	MP/layer:	8	MP/layer:	8
	Layer/pallet:	14	Layer/pallet:	14	Layer/pallet:	14	Layer/pallet:	14
CONTAINER PALLET	MP/pallet:	140	MP/pallet:	140	MP/pallet:	140	MP/pallet:	140
HIGH CUBE	MP/layer:	10	MP/layer:	10	MP/layer:	10	MP/layer:	10
	Layer/pallet:	14	Layer/pallet:	14	Layer/pallet:	14	Layer/pallet:	14
EAN								
BILL UNIT	9 006206 530083		9 006206 530090		9 006206 530106		9 006206 530113	

RIEDEL DRINK SPECIFIC GLASSWARE



0417/01
DRINK SPECIFIC
GLASSWARE
NEAT GLASS*



0417/02
DRINK SPECIFIC
GLASSWARE
ROCKS GLASS*



0417/03
DRINK SPECIFIC
GLASSWARE
FIZZ GLASS*



0417/04
DRINK SPECIFIC
GLASSWARE
HIGHBALL GLASS*



0417/05
DRINK SPECIFIC
GLASSWARE
NICK & NORA GLASS*

ITEM	fine crystal machine-made		fine crystal machine-made		fine crystal machine-made		fine crystal machine-made		fine crystal machine-made	
	Item no.:		Item no.:		Item no.:		Item no.:		Item no.:	
	0417/01		0417/02		0417/03		0417/04		0417/05	
	Height/glass:	77 mm	Height/glass:	83 mm	Height/glass:	163 mm	Height/glass:	154 mm	Height/glass:	153 mm
	Capacity/glass:	174 ccm	Capacity/glass:	283 ccm	Capacity/glass:	265 ccm	Capacity/glass:	310 ccm	Capacity/glass:	140 ccm
	Design:	2018	Design:	2018	Design:	2018	Design:	2018	Design:	2018
PACKAGING	Pieces/Bill unit:	1	Pieces/Bill unit:	1	Pieces/Bill unit:	1	Pieces/Bill unit:	1	Pieces/Bill unit:	1
TYPE AND QUANTITY	Bill units/MP:	12	Bill units/MP:	12	Bill units/MP:	12	Bill units/MP:	12	Bill units/MP:	12
MASTERPACK DIMENSIONS	Length:	300 mm	Length:	348 mm	Length:	260 mm	Length:	284 mm	Length:	334 mm
	Width:	223 mm	Width:	259 mm	Width:	193 mm	Width:	211 mm	Width:	245 mm
	Height:	85 mm	Height:	90 mm	Height:	171 mm	Height:	162 mm	Height:	160 mm
	Weight:	2944 gr	Weight:	4123 gr	Weight:	5207 gr	Weight:	5451 gr	Weight:	1586 gr
EURO PALLET	MP/pallet:	120	MP/pallet:	90	MP/pallet:	85	MP/pallet:	78	MP/pallet:	120
	MP/layer:	12	MP/layer:	9	MP/layer:	17	MP/layer:	13	MP/layer:	10
	Layer/pallet:	10	Layer/pallet:	10	Layer/pallet:	5	Layer/pallet:	6	Layer/pallet:	12
CONTAINER PALLET HIGH CUBE	MP/pallet:	192	MP/pallet:	143	MP/pallet:	96	MP/pallet:	108	MP/pallet:	196
	MP/layer:	16	MP/layer:	13	MP/layer:	24	MP/layer:	18	MP/layer:	14
	Layer/pallet:	12	Layer/pallet:	11	Layer/pallet:	4	Layer/pallet:	6	Layer/pallet:	14
EAN BILL UNIT										
	9 006206 528752		9 006206 528769		9 006206 528776		9 006206 528783		9 006206 528905	



DSG MOVIE





0417/06
DRINK SPECIFIC
GLASSWARE
SOUR GLASS*



0417/0
DRINK SPECIFIC
GLASSWARE
ALL PURPOSE GLASS*



0417/23
DRINK SPECIFIC
GLASSWARE
MIXING GLASS*

ITEM	fine crystal machine-made		fine crystal machine-made		fine crystal machine-made	
	Item no.:		Item no.:		Item no.:	
	0417/06		0417/0		0417/23	
	Height/glass:	158 mm	Height/glass:	187 mm	Height/glass:	176 mm
	Capacity/glass:	217 ccm	Capacity/glass:	350 ccm	Capacity/glass:	650 ccm
	Design:	2018	Design:	2019	Design:	2019
PACKAGING	Pieces/Bill unit:	1	Pieces/Bill unit:	1	Pieces/Bill unit:	1
TYPE AND QUANTITY	Bill units/MP:	12	Bill units/MP:	12	Bill units/MP:	4
MASTERPACK	Length:	424 mm	Length:	339 mm	Length:	199 mm
DIMENSIONS	Width:	315 mm	Width:	252 mm	Width:	199 mm
	Height:	179 mm	Height:	202 mm	Height:	204 mm
	Weight:	2065 gr	Weight:	1981 gr	Weight:	3651 gr
EURO PALLET	MP/pallet:	60	MP/pallet:	90	Bill units/pallet:	120
	MP/layer:	6	MP/layer:	10	Bill units/layer:	24
	Layer/pallet:	10	Layer/pallet:	9	Layers/pallet:	5
CONTAINER PALLET	MP/pallet:	117	MP/pallet:	154	Bill units/pallet:	150
HIGH CUBE	MP/layer:	9	MP/layer:	14	Bill units/layer:	30
	Layer/pallet:	13	Layer/pallet:	11	Layers/pallet:	5
EAN						
BILL UNIT	9 006206 528912		9 006206 529858		9 006206 529888	



0260/0
RIEDEL 001



0480/90
MAGNUM



0480/00
RED WINE



0480/08
CHAMPAGNE
GLASS



0480/05
WHITE WINE

ITEM	fine crystal machine-made		fine crystal machine-made		fine crystal machine-made		fine crystal machine-made		fine crystal machine-made	
	Item no.:	0260/0	Item no.:	0480/90	Item no.:	0480/00	Item no.:	0480/08	Item no.:	0480/05
	Height/glass:	261 mm	Height/glass:	201 mm	Height/glass:	187 mm	Height/glass:	224 mm	Height/glass:	180 mm
	Capacity/glass:	995 ccm	Capacity/glass:	530 ccm	Capacity/glass:	350 ccm	Capacity/glass:	290 ccm	Capacity/glass:	280 ccm
	Design:	2016	Design:	2007	Design:	2007	Design:	2007	Design:	2007
PACKAGING	Pieces/Bill unit:	1	Pieces/Bill unit:	1	Pieces/Bill unit:	1	Pieces/Bill unit:	1	Pieces/Bill unit:	1
TYPE AND QUANTITY	Bill units/MP:	12	Bill units/MP:	12	Bill units/MP:	12	Bill units/MP:	12	Bill units/MP:	12
MASTERPACK DIMENSIONS	Length:	462 mm	Length:	379 mm	Length:	339 mm	Length:	307 mm	Length:	319 mm
	Width:	345 mm	Width:	282 mm	Width:	252 mm	Width:	228 mm	Width:	237 mm
	Height:	273 mm	Height:	215 mm	Height:	202 mm	Height:	239 mm	Height:	193 mm
	Weight:	3497 gr	Weight:	2406 gr	Weight:	1981 gr	Weight:	1972 gr	Weight:	1756 gr
EURO PALLET	MP/pallet:	28	MP/pallet:	64	MP/pallet:	90	MP/pallet:	96	MP/pallet:	108
	MP/layer:	4	MP/layer:	8	MP/layer:	10	MP/layer:	12	MP/layer:	12
	Layer/pallet:	7	Layer/pallet:	8	Layer/pallet:	9	Layer/pallet:	8	Layer/pallet:	9
CONTAINER PALLET HIGH CUBE	MP/pallet:	56	MP/pallet:	110	MP/pallet:	154	MP/pallet:	162	MP/pallet:	192
	MP/layer:	7	MP/layer:	11	MP/layer:	14	MP/layer:	18	MP/layer:	16
	Layer/pallet:	8	Layer/pallet:	10	Layer/pallet:	11	Layer/pallet:	9	Layer/pallet:	12
EAN BILL UNIT										
	9 006206 525270		9 006206 513161		9 006206 513178		9 006206 513192		9 006206 513185	



MASTERPACK
0480/XX

MANHATTAN



0260/02
OUVERTURE
RIEDEL 002



0419/04
HIGHBALL



0419/02
DOUBLE
OLD FASHIONED



0419/01
SINGLE
OLD FASHIONED

ITEM	fine crystal machine-made	
	Item no.:	0260/02
	Height/glass:	247 mm
	Capacity/glass:	667 ccm
	Design:	2020
PACKAGING TYPE AND QUANTITY	Pieces/Bill unit:	1
	Bill units/MP:	12
MASTERPACK DIMENSIONS	Length:	449 mm
	Width:	330 mm
	Height:	252 mm
	Weight:	2959 gr
EURO PALLET	MP/pallet:	35
	MP/layer:	5
	Layer/pallet:	7
CONTAINER PALLET HIGH CUBE	MP/pallet:	63
	MP/layer:	7
	Layer/pallet:	9

EAN
BILL UNIT



fine crystal machine-made	fine crystal machine-made	fine crystal machine-made			
Item no.:	0419/04	Item no.:	0419/02	Item no.:	0419/01
Height/glass:	146 mm	Height/glass:	94 mm	Height/glass:	90 mm
Capacity/glass:	350 ccm	Capacity/glass:	370 ccm	Capacity/glass:	290 ccm
Design:	2014	Design:	2014	Design:	2014
Pieces/Bill unit:	1	Pieces/Bill unit:	1	Pieces/Bill unit:	1
Bill units/MP:	12	Bill units/MP:	12	Bill units/MP:	12
Length:	308 mm	Length:	365 mm	Length:	332 mm
Width:	233 mm	Width:	276 mm	Width:	252 mm
Height:	164 mm	Height:	111 mm	Height:	108 mm
Weight:	4515 gr	Weight:	3986 gr	Weight:	3266 gr
MP/pallet:	108	MP/pallet:	80	MP/pallet:	160
MP/layer:	12	MP/layer:	8	MP/layer:	10
Layer/pallet:	9	Layer/pallet:	10	Layer/pallet:	16
MP/pallet:	128	MP/pallet:	143	MP/pallet:	182
MP/layer:	16	MP/layer:	11	MP/layer:	14
Layer/pallet:	8	Layer/pallet:	13	Layer/pallet:	13



GLASSES

MANHATTAN

B A R T U M B L E R



0489/0
RED WINE



0489/48
CHAMPAGNE FLUTE



0489/01
WHITE WINE



0489/41
DEGUSTAZIONE
○

ITEM	fine crystal machine-made		fine crystal machine-made		fine crystal machine-made		fine crystal machine-made	
	Item no.:	0489/0	Item no.:	0489/48	Item no.:	0489/01	Item no.:	0489/41
	Height/glass:	224 mm	Height/glass:	224 mm	Height/glass:	205 mm	Height/glass:	118 mm
	Capacity/glass:	560 ccm	Capacity/glass:	212 ccm	Capacity/glass:	340 ccm	Capacity/glass:	570 ccm
	Design:	2010	Design:	2015	Design:	2010	Design:	2014
PACKAGING TYPE AND QUANTITY	Pieces/Bill unit:	1	Pieces/Bill unit:	1	Pieces/Bill unit:	1	Pieces/Bill unit:	1
	Bill units/MP:	12	Bill units/MP:	12	Bill units/MP:	12	Bill units/MP:	12
MASTERPACK DIMENSIONS	Length:	377 mm	Length:	337 mm	Length:	338 mm	Length:	404 mm
	Width:	282 mm	Width:	251 mm	Width:	255 mm	Width:	303 mm
	Height:	242 mm	Height:	238 mm	Height:	224 mm	Height:	135 mm
	Weight:	2508 gr	Weight:	1990 gr	Weight:	1957 gr	Weight:	1666 gr
EURO PALLET	MP/pallet:	56	MP/pallet:	80	MP/pallet:	80	MP/pallet:	84
	MP/layer:	8	MP/layer:	10	MP/layer:	10	MP/layer:	6
	Layer/pallet:	7	Layer/pallet:	8	Layer/pallet:	8	Layer/pallet:	14
CONTAINER PALLET HIGH CUBE	MP/pallet:	99	MP/pallet:	126	MP/pallet:	140	MP/pallet:	170
	MP/layer:	11	MP/layer:	14	MP/layer:	14	MP/layer:	10
	Layer/pallet:	9	Layer/pallet:	9	Layer/pallet:	10	Layer/pallet:	17
EAN BILL UNIT								
	9 006206 515820		9 006206 524105		9 006206 515837		9 006206 522806	



MASTERPACK
0489/XX

degustazione



0413/30
RED WINE



0413/33
WHITE WINE

ITEM	fine crystal machine-made		fine crystal machine-made	
	Item no.:		Item no.:	
	0413/30		0413/33	
	Height/glass:	120 mm	Height/glass:	103 mm
	Capacity/glass:	580 ccm	Capacity/glass:	380 ccm
	Design:	2010	Design:	2010
PACKAGING	Pieces/Bill unit:	1	Pieces/Bill unit:	1
TYPE AND QUANTITY	Bill units/MP:	12	Bill units/MP:	12
MASTERPACK	Length:	394 mm	Length:	335 mm
DIMENSIONS	Width:	296 mm	Width:	268 mm
	Height:	140 mm	Height:	121 mm
	Weight:	1850 gr	Weight:	1590 gr
EURO PALLET	MP/pallet:	104	MP/pallet:	160
	MP/layer:	8	MP/layer:	10
	Layer/pallet:	13	Layer/pallet:	16
CONTAINER PALLET	MP/pallet:	160	MP/pallet:	280
HIGH CUBE	MP/layer:	10	MP/layer:	14
	Layer/pallet:	16	Layer/pallet:	20

EAN
BILL UNIT



MASTERPACK
0413/XX



0446/18
TEQUILA
RIEDEL BAR



0446/71
COGNAC
RIEDEL BAR



0446/60
PORT
RIEDEL BAR



0446/11
BEER
RIEDEL BAR



0446/80
SINGLE MALT WHISKY
RIEDEL BAR



ITEM	fine crystal machine-made		fine crystal machine-made		fine crystal machine-made		fine crystal machine-made		fine crystal machine-made	
	Item no.:	0446/18	Item no.:	0446/71	Item no.:	0446/60	Item no.:	0446/11	Item no.:	0446/80
	Height/glass:	210 mm	Height/glass:	190 mm	Height/glass:	175 mm	Height/glass:	170 mm	Height/glass:	115 mm
	Capacity/glass:	190 ccm	Capacity/glass:	175 ccm	Capacity/glass:	265 ccm	Capacity/glass:	500 ccm	Capacity/glass:	200 ccm
	Design:	2006	Design:	2006	Design:	2011	Design:	2002	Design:	2008
PACKAGING	Pieces/Bill unit:	1	Pieces/Bill unit:	1	Pieces/Bill unit:	1	Pieces/Bill unit:	1	Pieces/Bill unit:	1
TYPE AND QUANTITY	Bill units/MP:	12	Bill units/MP:	12	Bill units/MP:	12	Bill units/MP:	12	Bill units/MP:	12
MASTERPACK DIMENSIONS	Length:	295 mm	Length:	311 mm	Length:	319 mm	Length:	368 mm	Length:	295 mm
	Width:	219 mm	Width:	230 mm	Width:	237 mm	Width:	275 mm	Width:	220 mm
	Height:	232 mm	Height:	199 mm	Height:	193 mm	Height:	186 mm	Height:	128 mm
	Weight:	1745 gr	Weight:	1765 gr	Weight:	1667 gr	Weight:	2276 gr	Weight:	1667 gr
EURO PALLET	MP/pallet:	104	MP/pallet:	108	MP/pallet:	108	MP/pallet:	80	MP/pallet:	195
	MP/layer:	13	MP/layer:	12	MP/layer:	12	MP/layer:	8	MP/layer:	13
	Layer/pallet:	8	Layer/pallet:	9	Layer/pallet:	9	Layer/pallet:	10	Layer/pallet:	15
CONTAINER PALLET HIGH CUBE	MP/pallet:	180	MP/pallet:	176	MP/pallet:	192	MP/pallet:	132	MP/pallet:	324
	MP/layer:	18	MP/layer:	16	MP/layer:	16	MP/layer:	11	MP/layer:	18
	Layer/pallet:	10	Layer/pallet:	11	Layer/pallet:	12	Layer/pallet:	12	Layer/pallet:	18
EAN BILL UNIT										
	9 006206 514861		9 006206 513963		9 006206 516193		9 006206 511990		9 006206 515455	



0480/02
WHISKY
RIEDEL BAR



0480/01
WATER
RIEDEL BAR

ITEM	fine crystal machine-made		fine crystal machine-made	
	Item no.:	0480/02	Item no.:	0480/01
	Height/glass:	100 mm	Height/glass:	80 mm
	Capacity/glass:	430 ccm	Capacity/glass:	330 ccm
	Design:	2009	Design:	2007
PACKAGING	Pieces/Bill unit:	1	Pieces/Bill unit:	1
TYPE AND QUANTITY	Bill units/MP:	12	Bill units/MP:	12
MASTERPACK	Length:	343 mm	Length:	343 mm
DIMENSIONS	Width:	255 mm	Width:	255 mm
	Height:	115 mm	Height:	94 mm
	Weight:	1919 gr	Weight:	1536 gr
EURO PALLET	MP/pallet:	160	MP/pallet:	200
	MP/layer:	10	MP/layer:	10
	Layer/pallet:	16	Layer/pallet:	20
CONTAINER PALLET	MP/pallet:	280	MP/pallet:	336
HIGH CUBE	MP/layer:	14	MP/layer:	14
	Layer/pallet:	20	Layer/pallet:	24
EAN	 9 006206 515448		 9 006206 513208	
BILL UNIT				



MASTERPACK
0480/XX

CALIBRATION MARK

COLLECTION ITEMS



0446/30-1
SYRAH

0,1 l + 0,2 l



0446/58-1
CHAMPAGNE
WINE GLASS

0,1 l



0446/48-1
CHAMPAGNE
GLASS

0,1 l



0446/0-1
CABERNET/
MERLOT

0,1 l + 0,2 l



0446/07-1
PINOT NOIR

0,1 l + 0,2 l

ITEM	fine crystal machine-made		fine crystal machine-made		fine crystal machine-made		fine crystal machine-made		fine crystal machine-made	
	Item no.:	0446/30-1	Item no.:	0446/58-1	Item no.:	0446/48-1	Item no.:	0446/0-1	Item no.:	0446/07-1
	Height/glass:	226 mm	Height/glass:	221 mm	Height/glass:	217 mm	Height/glass:	217 mm	Height/glass:	215 mm
	Capacity/glass:	650 ccm	Capacity/glass:	480 ccm	Capacity/glass:	260 ccm	Capacity/glass:	610 ccm	Capacity/glass:	700 ccm
	Design:	2016	Design:	2018	Design:	2016	Design:	2016	Design:	2016
PACKAGING TYPE AND QUANTITY	Pieces/Bill unit:	1	Pieces/Bill unit:	1	Pieces/Bill unit:	1	Pieces/Bill unit:	1	Pieces/Bill unit:	1
	Bill units/MP:	12	Bill units/MP:	12	Bill units/MP:	12	Bill units/MP:	12	Bill units/MP:	12
MASTERPACK DIMENSIONS	Length:	444 mm	Length:	367 mm	Length:	295 mm	Length:	444 mm	Length:	444 mm
	Width:	332 mm	Width:	271 mm	Width:	219 mm	Width:	332 mm	Width:	332 mm
	Height:	243 mm	Height:	230 mm	Height:	232 mm	Height:	243 mm	Height:	243 mm
	Weight:	2552 gr	Weight:	2244 gr	Weight:	1865 gr	Weight:	2642 gr	Weight:	2614 gr
EURO PALLET	MP/pallet:	35	MP/pallet:	64	MP/pallet:	104	MP/pallet:	35	MP/pallet:	35
	MP/layer:	5	MP/layer:	8	MP/layer:	13	MP/layer:	5	MP/layer:	5
	Layer/pallet:	7	Layer/pallet:	8	Layer/pallet:	8	Layer/pallet:	7	Layer/pallet:	7
CONTAINER PALLET HIGH CUBE	MP/pallet:	72	MP/pallet:	110	MP/pallet:	180	MP/pallet:	72	MP/pallet:	72
	MP/layer:	8	MP/layer:	11	MP/layer:	18	MP/layer:	8	MP/layer:	8
	Layer/pallet:	9	Layer/pallet:	10	Layer/pallet:	10	Layer/pallet:	9	Layer/pallet:	9
EAN BILL UNIT										
	9 006206 525225		9 006206 527342		9 006206 524464		9 006206 524433		9 006206 525232	



MASTERPACK
0446/XX



0446/15-1
RIESLING/
ZINFANDEL
0,1 l + 0,2 l



0446/05-1
CHARDONNAY/
VIOGNIER



0446/97-1
OAKED
CHARDONNAY
0,1 l + 0,2 l

ITEM	fine crystal machine-made		fine crystal machine-made		fine crystal machine-made	
	Item no.:		Item no.:		Item no.:	
	0446/15-1		0446/05-1		0446/97-1	
	Height/glass:	214 mm	Height/glass:	203 mm	Height/glass:	197 mm
	Capacity/glass:	370 ccm	Capacity/glass:	350 ccm	Capacity/glass:	700 ccm
	Design:	2016	Design:	2016	Design:	2016
PACKAGING TYPE AND QUANTITY	Pieces/Bill unit:	1	Pieces/Bill unit:	1	Pieces/Bill unit:	1
	Bill units/MP:	12	Bill units/MP:	12	Bill units/MP:	12
MASTERPACK DIMENSIONS	Length:	368 mm	Length:	368 mm	Length:	444 mm
	Width:	275 mm	Width:	275 mm	Width:	332 mm
	Height:	244 mm	Height:	244 mm	Height:	243 mm
	Weight:	2130 gr	Weight:	2102 gr	Weight:	2695 gr
EURO PALLET	MP/pallet:	56	MP/pallet:	56	MP/pallet:	35
	MP/layer:	8	MP/layer:	8	MP/layer:	5
	Layer/pallet:	7	Layer/pallet:	7	Layer/pallet:	7
CONTAINER PALLET HIGH CUBE	MP/pallet:	99	MP/pallet:	99	MP/pallet:	72
	MP/layer:	11	MP/layer:	11	MP/layer:	8
	Layer/pallet:	9	Layer/pallet:	9	Layer/pallet:	9

EAN BILL UNIT

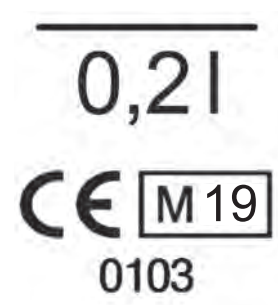

According to EU Directive 2004/22/EC 2004.

CALIBRATION MARK

COLLECTION ITEMS



0446/30-M
SYRAH



0446/58-M
CHAMPAGNE
WINE GLASS
0,1 l







0446/48-M
CHAMPAGNE
GLASS



0446/0-M
CABERNET/
MERLOT



0446/07-M
PINOT NOIR

ITEM	fine crystal machine-made		fine crystal machine-made		fine crystal machine-made		fine crystal machine-made		fine crystal machine-made	
	Item no.:	0446/30-M	Item no.:	0446/58-M	Item no.:	0446/48-M	Item no.:	0446/0-M	Item no.:	0446/07-M
	Height/glass:	226 mm	Height/glass:	221 mm	Height/glass:	217 mm	Height/glass:	217 mm	Height/glass:	215 mm
	Capacity/glass:	650 ccm	Capacity/glass:	440 ccm	Capacity/glass:	260 ccm	Capacity/glass:	610 ccm	Capacity/glass:	700 ccm
	Design:	2016	Design:	2018	Design:	2016	Design:	2016	Design:	2016
PACKAGING TYPE AND QUANTITY	Pieces/Bill unit:	1	Pieces/Bill unit:	1	Pieces/Bill unit:	1	Pieces/Bill unit:	1	Pieces/Bill unit:	1
	Bill units/MP:	12	Bill units/MP:	12	Bill units/MP:	12	Bill units/MP:	12	Bill units/MP:	12
MASTERPACK DIMENSIONS	Length:	444 mm	Length:	367 mm	Length:	295 mm	Length:	444 mm	Length:	444 mm
	Width:	332 mm	Width:	271 mm	Width:	219 mm	Width:	332 mm	Width:	332 mm
	Height:	243 mm	Height:	230 mm	Height:	232 mm	Height:	243 mm	Height:	243 mm
	Weight:	2552 gr	Weight:	2244 gr	Weight:	1865 gr	Weight:	2642 gr	Weight:	2614 gr
EURO PALLET	MP/pallet:	35	MP/pallet:	64	MP/pallet:	104	MP/pallet:	35	MP/pallet:	35
	MP/layer:	5	MP/layer:	8	MP/layer:	13	MP/layer:	5	MP/layer:	5
	Layer/pallet:	7	Layer/pallet:	8	Layer/pallet:	8	Layer/pallet:	7	Layer/pallet:	7
CONTAINER PALLET HIGH CUBE	MP/pallet:	72	MP/pallet:	110	MP/pallet:	180	MP/pallet:	72	MP/pallet:	72
	MP/layer:	8	MP/layer:	11	MP/layer:	18	MP/layer:	8	MP/layer:	8
	Layer/pallet:	9	Layer/pallet:	10	Layer/pallet:	10	Layer/pallet:	9	Layer/pallet:	9
EAN BILL UNIT										
	9 006206 524815		9 006206 527496		9 006206 524914		9 006206 524792		9 006206 524839	



BILL UNIT
0446/XX





0446/15-M
RIESLING/
ZINFANDEL



0446/05-M
CHARDONNAY/
VIOGNIER



0446/97-M
OAKED
CHARDONNAY

ITEM	fine crystal machine-made		fine crystal machine-made		fine crystal machine-made	
	Item no.:		Item no.:		Item no.:	
	0446/15-M		0446/05-M		0446/97-M	
	Height/glass:	214 mm	Height/glass:	203 mm	Height/glass:	195 mm
	Capacity/glass:	370 ccm	Capacity/glass:	350 ccm	Capacity/glass:	700 ccm
	Design:	2016	Design:	2016	Design:	2016
PACKAGING TYPE AND QUANTITY	Pieces/Bill unit:	1	Pieces/Bill unit:	1	Pieces/Bill unit:	1
	Bill units/MP:	12	Bill units/MP:	12	Bill units/MP:	12
MASTERPACK DIMENSIONS	Length:	368 mm	Length:	368 mm	Length:	444 mm
	Width:	275 mm	Width:	275 mm	Width:	332 mm
	Height:	244 mm	Height:	244 mm	Height:	243 mm
	Weight:	2130 gr	Weight:	2102 gr	Weight:	2695 gr
EURO PALLET	MP/pallet:	56	MP/pallet:	8	MP/pallet:	35
	MP/layer:	8	MP/layer:	7	MP/layer:	5
	Layer/pallet:	7	Layer/pallet:	56	Layer/pallet:	7
CONTAINER PALLET HIGH CUBE	MP/pallet:	99	MP/pallet:	11	MP/pallet:	72
	MP/layer:	11	MP/layer:	9	MP/layer:	8
	Layer/pallet:	9	Layer/pallet:	99	Layer/pallet:	9
EAN BILL UNIT	 9 006206 524853		 9 006206 524877		 9 006206 524891	



CALIBRATION MARK

COLLECTION ITEMS



0454/0-1
EXTREME RESTAURANT
CABERNET
0,1 l + 0,2 l



0454/32-1
EXTREME RESTAURANT
SHIRAZ
0,1 l + 0,2 l



0454/05-1
EXTREME RESTAURANT
SAUVIGNON BLANC
0,1 l + 0,2 l



0454/55-1
EXTREME RESTAURANT
ROSÉ/CHAMPAGNERGLAS
0,1 l



0489/0-1
DEGUSTAZIONE
ROTWEIN
0,1 l + 0,2 l

ITEM	fine crystal machine-made		fine crystal machine-made		fine crystal machine-made		fine crystal machine-made		fine crystal machine-made	
	Item no.:	0454/0-1	Item no.:	0454/32-1	Item no.:	0454/05-1	Item no.:	0454/55-1	Item no.:	0489/0-1
	Height/glass:	247 mm	Height/glass:	244 mm	Height/glass:	240 mm	Height/glass:	230 mm	Height/glass:	224 mm
	Capacity/glass:	800 ccm	Capacity/glass:	709 ccm	Capacity/glass:	460 ccm	Capacity/glass:	322 ccm	Capacity/glass:	560 ccm
	Design:	2019	Design:	2019	Design:	2019	Design:	2019	Design:	2019
PACKAGING	Pieces/Bill unit:	1	Pieces/Bill unit:	1	Pieces/Bill unit:	1	Pieces/Bill unit:	1	Pieces/Bill unit:	1
TYPE AND QUANTITY	Bill units/MP:	12	Bill units/MP:	12	Bill units/MP:	12	Bill units/MP:	12	Bill units/MP:	12
MASTERPACK DIMENSIONS	Length:	443 mm	Length:	443 mm	Length:	371 mm	Length:	371 mm	Length:	377 mm
	Width:	330 mm	Width:	330 mm	Width:	276 mm	Width:	276 mm	Width:	282 mm
	Height:	261 mm	Height:	261 mm	Height:	254 mm	Height:	254 mm	Height:	242 mm
	Weight:	2460 gr	Weight:	2822 mm	Weight:	2458 gr	Weight:	2269 gr	Weight:	2508 gr
EURO PALLET	MP/pallet:	35	MP/pallet:	35	MP/pallet:	56	MP/pallet:	56	MP/pallet:	56
	MP/layer:	5	MP/layer:	5	MP/layer:	8	MP/layer:	8	MP/layer:	8
	Layer/pallet:	7	Layer/pallet:	7	Layer/pallet:	7	Layer/pallet:	7	Layer/pallet:	7
CONTAINER PALLET HIGH CUBE	MP/pallet:	64	MP/pallet:	64	MP/pallet:	99	MP/pallet:	99	MP/pallet:	99
	MP/layer:	8	MP/layer:	8	MP/layer:	11	MP/layer:	11	MP/layer:	11
	Layer/pallet:	8	Layer/pallet:	8	Layer/pallet:	9	Layer/pallet:	9	Layer/pallet:	9
EAN BILL UNIT										
	9 006206 524457		9 006206 529216		9 006206 529193		9 006206 529230		9 006206 524426	



0489/48-1
 DEGUSTAZIONE
 CHAMPAGNER FLÖTE
 0,1 l

ITEM	fine crystal	
	machine-made	
	Item no.:	0489/48-1
	Height/glass:	224 mm
	Capacity/glass:	212 ccm
	Design:	2019

PACKAGING TYPE AND QUANTITY	Pieces/Bill unit:	1
	Bill units/MP:	12

MASTERPACK DIMENSIONS	Length:	337 mm
	Width:	251 mm
	Height:	238 mm
	Weight:	1990 gr

EURO PALLET	MP/pallet:	80
	MP/layer:	10
	Layer/pallet:	8

CONTAINER PALLET HIGH CUBE	MP/pallet:	126
	MP/layer:	14
	Layer/pallet:	9

EAN
BILL UNIT



ACCESSORIES



5010/07
MICROFIBER
POLISHING CLOTHS



0010/07
MICROFIBER
POLISHING CLOTH

ITEM		5010/07	0010/07
	Item no.:	5010/07	0010/07
	Height/glass:	0 mm	0 mm
	Capacity/glass:	0 ccm	0 ccm
	Design:	2010	2006
PACKAGING	Pieces/Bill unit:	1	1
TYPE AND QUANTITY	Bill units/MP:	20	1
MASTERPACK	Length:	297 mm	285 mm
DIMENSIONS	Width:	228 mm	186 mm
	Height:	182 mm	6 mm
	Weight:	1780 gr	92 gr
EURO PALLET	MP/pallet:	130	4500
	MP/layer:	13	750
	Layer/pallet:	10	6
CONTAINER PALLET	MP/pallet:	220	10000
HIGH CUBE	MP/layer:	22	1250
	Layer/pallet:	10	8

**EAN
BILL UNIT**



DECANTER MACHINE-MADE NO R.Q. AVAILABLE



1486/13
SYRAH

		1486/13
	Item no.:	1486/13
	Height/glass:	245 mm
	Capacity/glass:	1040 ccm
	Design:	2017
	Pieces/Bill unit:	1
	Bill units/MP:	6
	Length:	446 mm
	Width:	297 mm
	Height:	264 mm
	Weight:	2120 gr
	MP/pallet:	42
	MP/layer:	6
	Layer/pallet:	7
	MP/pallet:	72
	MP/layer:	9
	Layer/pallet:	8



DECANTER
MACHINE-MADE
NO R.Q. AVAILABLE



1496/13
PERFORMANCE



1446/14
MERLOT



1466/13
RIEDEL APPLE NY



1446/05
MINI DECANTER

ITEM	fine crystal machine-made		fine crystal machine-made		fine crystal machine-made		fine crystal machine-made	
	Item no.:		Item no.:		Item no.:		Item no.:	
	1496/13		1446/14		1466/13		1446/05	
	Height/glass:	245 mm	Height/glass:	240 mm	Height/glass:	195 mm	Height/glass:	160 mm
	Capacity/glass:	1040 ccm	Capacity/glass:	970 ccm	Capacity/glass:	1500 ccm	Capacity/glass:	400 ccm
	Design:	2018	Design:	2004	Design:	2014	Design:	2012
PACKAGING TYPE AND QUANTITY	Pieces/Bill unit:	1	Pieces/Bill unit:	1	Pieces/Bill unit:	1	Pieces/Bill unit:	1
	Bill units/MP:	6	Bill units/MP:	6	Bill units/MP:	6	Bill units/MP:	12
MASTERPACK DIMENSIONS	Length:	446 mm	Length:	359 mm	Length:	417 mm	Length:	368 mm
	Width:	297 mm	Width:	245 mm	Width:	282 mm	Width:	275 mm
	Height:	264 mm	Height:	253 mm	Height:	202 mm	Height:	186 mm
	Weight:	2048 gr	Weight:	1915 gr	Weight:	2042 gr	Weight:	2106 gr
EURO PALLET	MP/pallet:	42	MP/pallet:	63	MP/pallet:	54	MP/pallet:	960
	MP/layer:	6	MP/layer:	9	MP/layer:	6	MP/layer:	96
	Layer/pallet:	7	Layer/pallet:	7	Layer/pallet:	9	Layer/pallet:	10
CONTAINER PALLET HIGH CUBE	MP/pallet:	72	MP/pallet:	117	MP/pallet:	99	MP/pallet:	1584
	MP/layer:	9	MP/layer:	13	MP/layer:	9	MP/layer:	132
	Layer/pallet:	8	Layer/pallet:	9	Layer/pallet:	11	Layer/pallet:	12
EAN BILL UNIT								
	9 006206 528233		9 006206 513130		9 006206 311628		9 006206 519040	

DECANTER
HAND-MADE

THE ART OF DECANTING WINE



FATTO A MANO MAMBA DECANTER 1950/00, FATTO A MANO PINOT NOIR 4905/07BWT,
FATTO A MANO OAKED CHARDONNAY 4905/97BWT, O WINE TUMBLER WHISKY/H2O 0414/02



DECANTER

DECANTER
HAND-MADE
FIRST QUALITY



2021/01-G
AYAM GRIGIO
DECANTER



2021/01-M
AYAM MENTA
DECANTER



2021/01-R
AYAM ROSA
DECANTER



2007/14
SWAN MINI
DECANTER

ITEM	fine crystal hand-made		fine crystal hand-made		fine crystal hand-made		fine crystal hand-made	
	Item no.:	2021/01-G	Item no.:	2021/01-M	Item no.:	2021/01-R	Item no.:	2007/14
	Height/glass:	312 mm	Height/glass:	312 mm	Height/glass:	312 mm	Height/glass:	480 mm
	Capacity/glass:	2900 ccm	Capacity/glass:	2900 ccm	Capacity/glass:	2900 ccm	Capacity/glass:	375 ccm
	Design:	2021	Design:	2021	Design:	2021	Design:	2021
PACKAGING TYPE AND QUANTITY	Pieces/Bill unit:	1	Pieces/Bill unit:	1	Pieces/Bill unit:	1	Pieces/Bill unit:	1
	Bill units/MP:	1	Bill units/MP:	1	Bill units/MP:	1	Bill units/MP:	1
BILL UNIT DIMENSIONS	Length:	303 mm	Length:	303 mm	Length:	303 mm	Length:	279 mm
	Width:	183 mm	Width:	183 mm	Width:	183 mm	Width:	275 mm
	Height:	458 mm	Height:	458 mm	Height:	458 mm	Height:	551 mm
	Weight:	1147 gr	Weight:	1147 gr	Weight:	1147 gr	Weight:	896 gr
MASTERPACK DIMENSIONS	Length:	314 mm	Length:	314 mm	Length:	314 mm	Length:	290 mm
	Width:	194 mm	Width:	194 mm	Width:	194 mm	Width:	281 mm
	Height:	464 mm	Height:	464 mm	Height:	464 mm	Height:	556 mm
	Weight:	1323 gr	Weight:	1323 gr	Weight:	1323 gr	Weight:	1134 gr
EURO PALLET	Bill units/pallet:	56	Bill units/pallet:	56	Bill units/pallet:	56	Bill units/pallet:	24
	Bill units/layer:	14	Bill units/layer:	14	Bill units/layer:	14	Bill units/layer:	4
	Layers/pallet:	4	Layers/pallet:	4	Layers/pallet:	4	Layers/pallet:	6
CONTAINER PALLET HIGH CUBE	Bill units/pallet:	100	Bill units/pallet:	100	Bill units/pallet:	100	Bill units/pallet:	48
	Bill units/layer:	20	Bill units/layer:	20	Bill units/layer:	20	Bill units/layer:	6
	Layers/pallet:	5	Layers/pallet:	5	Layers/pallet:	5	Layers/pallet:	8
EAN BILL UNIT								



Limited Editions: TG reserves the right to offer glassware marked as "Limited Edition" in a certain amount and for a certain time period and under certain allocation criteria to Customer.

**R.Q. (RESTAURANT QUALITY) OF
HAND-MADE DECANTERS ONLY UPON AVAILABILITY.**



2021/55
RIEDEL SAKURA
DECANTER



2009/21 S1
RIEDEL CHINESE ZODIAC
OX DECANTER



2344/01
RIEDEL ALTITUDE MATTERS
DECANTER

ITEM	fine crystal hand-made		fine crystal hand-made		fine crystal hand-made	
	Item no.:	2021/55	Item no.:	2009/21 S1	Item no.:	2344/01
	Height/glass:	365 mm	Height/glass:	365 mm	Height/glass:	185 mm
	Capacity/glass:	1210 ccm	Capacity/glass:	1210 ccm	Capacity/glass:	750 ccm
	Design:	2021	Design:	2021	Design:	2021
PACKAGING TYPE AND QUANTITY	Pieces/Bill unit:	1	Pieces/Bill unit:	1	Pieces/Bill unit:	1
	Bill units/MP:	1	Bill units/MP:	1	Bill units/MP:	1
BILL UNIT DIMENSIONS	Length:	172 mm	Length:	172 mm	Length:	485 mm
	Width:	172 mm	Width:	172 mm	Width:	203 mm
	Height:	476 mm	Height:	476 mm	Height:	204 mm
	Weight:	990 gr	Weight:	990 gr	Weight:	1734 gr
MASTERPACK DIMENSIONS	Length:	177 mm	Length:	177 mm	Length:	489 mm
	Width:	177 mm	Width:	177 mm	Width:	209 mm
	Height:	477 mm	Height:	477 mm	Height:	209 mm
	Weight:	1121 gr	Weight:	1121 gr	Weight:	1910 gr
EURO PALLET	Bill units/pallet:	90	Bill units/pallet:	90	Bill units/pallet:	63
	Bill units/layer:	9	Bill units/layer:	9	Bill units/layer:	7
	Layers/pallet:	10	Layers/pallet:	10	Layers/pallet:	9
CONTAINER PALLET HIGH CUBE	Bill units/pallet:	182	Bill units/pallet:	182	Bill units/pallet:	132
	Bill units/layer:	14	Bill units/layer:	14	Bill units/layer:	12
	Layers/pallet:	13	Layers/pallet:	13	Layers/pallet:	11

EAN
BILL UNIT



DECANTER
HAND-MADE
FIRST QUALITY





1756/80
AMADEO
DOUBLE MAGNUM



2012/68
TWENTY TWELVE
RED/BLACK



2014/02
HORN

ITEM	fine crystal hand-made		fine crystal hand-made		fine crystal hand-made	
	Item no.:	1756/80	Item no.:	2012/68	Item no.:	2014/02
	Height/glass:	680 mm	Height/glass:	355 mm	Height/glass:	370 mm
	Capacity/glass:	3000 ccm	Capacity/glass:	1850 ccm	Capacity/glass:	2500 ccm
	Design:	2014	Design:	2011	Design:	2014
PACKAGING	Pieces/Bill unit:	1	Pieces/Bill unit:	1	Pieces/Bill unit:	1
TYPE AND QUANTITY	Bill units/MP:	1	Bill units/MP:	1	Bill units/MP:	1
BILL UNIT DIMENSIONS	Length:	412 mm	Length:	275 mm	Length:	279 mm
	Width:	207 mm	Width:	225 mm	Width:	275 mm
	Height:	755 mm	Height:	632 mm	Height:	551 mm
	Weight:	3000 gr	Weight:	1402 gr	Weight:	1346 gr
MASTERPACK DIMENSIONS	Length:	422 mm	Length:	286 mm	Length:	290 mm
	Width:	218 mm	Width:	234 mm	Width:	281 mm
	Height:	766 mm	Height:	634 mm	Height:	556 mm
	Weight:	3500 gr	Weight:	1650 gr	Weight:	4584 gr
EURO PALLET	Bill units/pallet:	20	Bill units/pallet:	30	Bill units/pallet:	24
	Bill units/layer:	5	Bill units/layer:	5	Bill units/layer:	4
	Layers/pallet:	4	Layers/pallet:	6	Layers/pallet:	6
CONTAINER PALLET HIGH CUBE	Bill units/pallet:	36	Bill units/pallet:	54	Bill units/pallet:	48
	Bill units/layer:	12	Bill units/layer:	6	Bill units/layer:	6
	Layers/pallet:	3	Layers/pallet:	7	Layers/pallet:	8
EAN BILL UNIT	 9 006206 214051		 9 006206 213146		 9 006206 311743	



BILL UNIT
1756/80



BILL UNIT

**R.Q. (RESTAURANT QUALITY) OF
HAND-MADE DECANTERS ONLY UPON AVAILABILITY.**



4100/23
BLACK TIE



2007/01
FLAMINGO



2014/14
HORN MINI
DECANTER



1405/13
TYROL

ITEM	fine crystal hand-made		fine crystal hand-made		fine crystal hand-made		fine crystal hand-made	
	Item no.:	4100/23	Item no.:	2007/01	Item no.:	2014/14	Item no.:	1405/13
	Height/glass:	420 mm	Height/glass:	600 mm	Height/glass:	265 mm	Height/glass:	192 mm
	Capacity/glass:	1955 ccm	Capacity/glass:	1880 ccm	Capacity/glass:	670 ccm	Capacity/glass:	1870 ccm
	Design:	2009	Design:	2008	Design:	2019	Design:	2007
PACKAGING TYPE AND QUANTITY	Pieces/Bill unit:	1	Pieces/Bill unit:	1	Pieces/Bill unit:	1	Pieces/Bill unit:	1
	Bill units/MP:	1	Bill units/MP:	1	Bill units/MP:	1	Bill units/MP:	1
BILL UNIT DIMENSIONS	Length:	279 mm	Length:	275 mm	Length:	291 mm	Length:	279 mm
	Width:	275 mm	Width:	225 mm	Width:	198 mm	Width:	275 mm
	Height:	551 mm	Height:	632 mm	Height:	224 mm	Height:	551 mm
	Weight:	1246 gr	Weight:	1462 gr	Weight:	623 gr	Weight:	1746 gr
MASTERPACK DIMENSIONS	Length:	290 mm	Length:	286 mm	Length:	291 mm	Length:	290 mm
	Width:	281 mm	Width:	234 mm	Width:	198 mm	Width:	281 mm
	Height:	556 mm	Height:	634 mm	Height:	224 mm	Height:	556 mm
	Weight:	1484 gr	Weight:	1710 gr	Weight:	623 gr	Weight:	1984 gr
EURO PALLET	Bill units/pallet:	24	Bill units/pallet:	30	Bill units/pallet:	128	Bill units/pallet:	24
	Bill units/layer:	4	Bill units/layer:	5	Bill units/layer:	16	Bill units/layer:	4
	Layers/pallet:	6	Layers/pallet:	6	Layers/pallet:	8	Layers/pallet:	6
CONTAINER PALLET HIGH CUBE	Bill units/pallet:	48	Bill units/pallet:	54	Bill units/pallet:	224	Bill units/pallet:	48
	Bill units/layer:	6	Bill units/layer:	6	Bill units/layer:	28	Bill units/layer:	6
	Layers/pallet:	8	Layers/pallet:	9	Layers/pallet:	8	Layers/pallet:	8

EAN
BILL UNIT



Limited Editions: TG reserves the right to offer glassware marked as "Limited Edition" in a certain amount and for a certain time period and under certain allocation criteria to Customer.

DECANTER
HAND-MADE
FIRST QUALITY



4101/13
HORSE







1950/09
EVE



1950/19
MAMBA



4100/13
BLACK TIE
FACE TO FACE

ITEM	fine crystal hand-made		fine crystal hand-made		fine crystal hand-made		fine crystal hand-made	
	Item no.:	4101/13	Item no.:	1950/09	Item no.:	1950/19	Item no.:	4100/13
	Height/glass:	600 mm	Height/glass:	505 mm	Height/glass:	325 mm	Height/glass:	600 mm
	Capacity/glass:	1766 ccm	Capacity/glass:	1370 ccm	Capacity/glass:	1500 ccm	Capacity/glass:	1766 ccm
	Design:	2014	Design:	2009	Design:	2011	Design:	2009
PACKAGING TYPE AND QUANTITY	Pieces/Bill unit:	1	Pieces/Bill unit:	1	Pieces/Bill unit:	1	Pieces/Bill unit:	1
	Bill units/MP:	1	Bill units/MP:	1	Bill units/MP:	1	Bill units/MP:	1
BILL UNIT DIMENSIONS	Length:	275 mm	Length:	279 mm	Length:	420 mm	Length:	275 mm
	Width:	225 mm	Width:	275 mm	Width:	267 mm	Width:	225 mm
	Height:	632 mm	Height:	551 mm	Height:	435 mm	Height:	632 mm
	Weight:	1532 gr	Weight:	1346 gr	Weight:	1660 gr	Weight:	1950 gr
MASTERPACK DIMENSIONS	Length:	286 mm	Length:	290 mm	Length:	425 mm	Length:	286 mm
	Width:	234 mm	Width:	281 mm	Width:	273 mm	Width:	234 mm
	Height:	634 mm	Height:	556 mm	Height:	445 mm	Height:	634 mm
	Weight:	1780 gr	Weight:	1584 gr	Weight:	2020 gr	Weight:	2300 gr
EURO PALLET	Bill units/pallet:	30	Bill units/pallet:	24	Bill units/pallet:	24	Bill units/pallet:	30
	Bill units/layer:	5	Bill units/layer:	4	Bill units/layer:	6	Bill units/layer:	5
	Layers/pallet:	6	Layers/pallet:	6	Layers/pallet:	4	Layers/pallet:	6
CONTAINER PALLET HIGH CUBE	Bill units/pallet:	54	Bill units/pallet:	48	Bill units/pallet:	45	Bill units/pallet:	54
	Bill units/layer:	6	Bill units/layer:	6	Bill units/layer:	9	Bill units/layer:	6
	Layers/pallet:	9	Layers/pallet:	8	Layers/pallet:	5	Layers/pallet:	9
EAN BILL UNIT	 9 006206 311798		 9 006206 311422		 9 006206 311484		 9 006206 311446	

CAUTION: the indented design feature of this decanter must not be used as a handle. Do not insert your hand or any item into the indented area. Cleaning beads should not be used. Carefully hand wash only.



BILL UNIT
1950/09





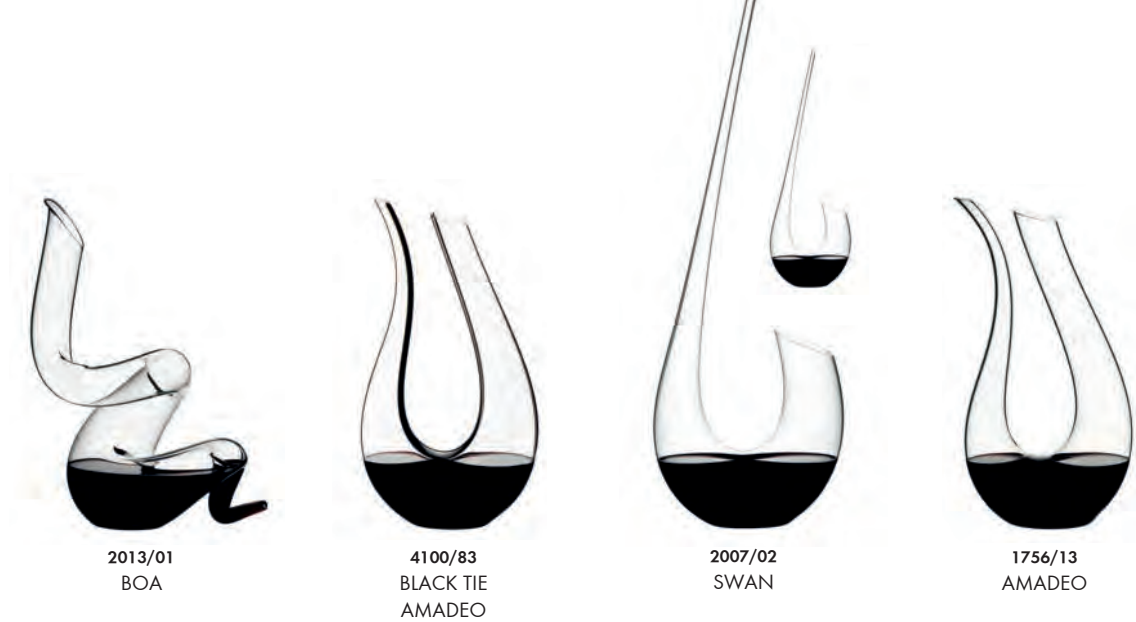

BILL UNIT
1950/19

CAUTION: the indented design feature of this decanter must not be used as a handle. Do not insert your hand or any item into the indented area. Cleaning beads should not be used. Carefully hand wash only.

R.Q. (RESTAURANT QUALITY) OF HAND-MADE DECANTERS ONLY UPON AVAILABILITY.



ITEM	fine crystal hand-made		fine crystal hand-made		fine crystal hand-made		fine crystal hand-made	
	Item no.:	2013/01	Item no.:	4100/83	Item no.:	2007/02	Item no.:	1756/13
	Height/glass:	350 mm	Height/glass:	350 mm	Height/glass:	600 mm	Height/glass:	350 mm
	Capacity/glass:	1957 ccm	Capacity/glass:	1500 ccm	Capacity/glass:	1570 ccm	Capacity/glass:	1500 ccm
	Design:	2013	Design:	2009	Design:	2008	Design:	2006
PACKAGING	Pieces/Bill unit:	1	Pieces/Bill unit:	1	Pieces/Bill unit:	1	Pieces/Bill unit:	1
TYPE AND QUANTITY	Bill units/MP:	1	Bill units/MP:	1	Bill units/MP:	1	Bill units/MP:	1
BILL UNIT DIMENSIONS	Length:	279 mm	Length:	303 mm	Length:	275 mm	Length:	303 mm
	Width:	275 mm	Width:	183 mm	Width:	225 mm	Width:	183 mm
	Height:	551 mm	Height:	458 mm	Height:	632 mm	Height:	458 mm
	Weight:	1316 gr	Weight:	1067 gr	Weight:	1162 gr	Weight:	1097 gr
MASTERPACK DIMENSIONS	Length:	290 mm	Length:	314 mm	Length:	286 mm	Length:	314 mm
	Width:	281 mm	Width:	194 mm	Width:	234 mm	Width:	194 mm
	Height:	556 mm	Height:	464 mm	Height:	634 mm	Height:	464 mm
	Weight:	1554 gr	Weight:	1243 gr	Weight:	1410 gr	Weight:	1273 gr
EURO PALLET	Bill units/pallet:	24	Bill units/pallet:	56	Bill units/pallet:	30	Bill units/pallet:	56
	Bill units/layer:	4	Bill units/layer:	14	Bill units/layer:	5	Bill units/layer:	14
	Layers/pallet:	6	Layers/pallet:	4	Layers/pallet:	6	Layers/pallet:	4
CONTAINER PALLET HIGH CUBE	Bill units/pallet:	48	Bill units/pallet:	100	Bill units/pallet:	54	Bill units/pallet:	100
	Bill units/layer:	6	Bill units/layer:	20	Bill units/layer:	6	Bill units/layer:	20
	Layers/pallet:	8	Layers/pallet:	5	Layers/pallet:	9	Layers/pallet:	5
EAN BILL UNIT								
	9 006206 213672		9 006206 311408		9 006206 311385		9 006206 212736	



BILL UNIT
2013/01



DECANTER
HAND-MADE
FIRST QUALITY



1756/13-G
DECANTER
 AMADEO GRIGIO







1756/13-M
DECANTER
 AMADEO MENTA



1756/13-R
DECANTER
 AMADEO ROSA



1950/14
MAMBA MINI
DECANTER

ITEM	fine crystal hand-made		fine crystal hand-made		fine crystal hand-made		fine crystal hand-made	
	Item no.:	1756/13-G	Item no.:	1756/13-M	Item no.:	1756/13-R	Item no.:	1950/14
	Height/glass:	350 mm	Height/glass:	350 mm	Height/glass:	350 mm	Height/glass:	255 mm
	Capacity/glass:	1500 ccm	Capacity/glass:	1500 ccm	Capacity/glass:	1500 ccm	Capacity/glass:	1075 ccm
	Design:	2019	Design:	2019	Design:	2019	Design:	2019
PACKAGING	Pieces/Bill unit:	1	Pieces/Bill unit:	1	Pieces/Bill unit:	1	Pieces/Bill unit:	1
TYPE AND QUANTITY	Bill units/MP:	1	Bill units/MP:	1	Bill units/MP:	1	Bill units/MP:	1
BILL UNIT	Length:	303 mm	Length:	303 mm	Length:	303 mm	Length:	290 mm
DIMENSIONS	Width:	183 mm	Width:	183 mm	Width:	183 mm	Width:	290 mm
	Height:	458 mm	Height:	458 mm	Height:	458 mm	Height:	308 mm
	Weight:	1097 gr	Weight:	1097 gr	Weight:	1097 gr	Weight:	691 gr
MASTERPACK	Length:	314 mm	Length:	314 mm	Length:	314 mm	Length:	299 mm
DIMENSIONS	Width:	194 mm	Width:	194 mm	Width:	194 mm	Width:	299 mm
	Height:	464 mm	Height:	464 mm	Height:	464 mm	Height:	314 mm
	Weight:	1273 gr	Weight:	1273 gr	Weight:	1273 gr	Weight:	830 gr
EURO PALLET	Bill units/pallet:	56	Bill units/pallet:	56	Bill units/pallet:	56	Bill units/pallet:	48
	Bill units/layer:	14	Bill units/layer:	14	Bill units/layer:	14	Bill units/layer:	8
	Layers/pallet:	4	Layers/pallet:	4	Layers/pallet:	4	Layers/pallet:	6
CONTAINER PALLET	Bill units/pallet:	100	Bill units/pallet:	100	Bill units/pallet:	100	Bill units/pallet:	84
HIGH CUBE	Bill units/layer:	20	Bill units/layer:	20	Bill units/layer:	20	Bill units/layer:	12
	Layers/pallet:	5	Layers/pallet:	5	Layers/pallet:	5	Layers/pallet:	7
EAN								
BILL UNIT	9 006206 313297		9 006206 313303		9 006206 313327		9 006206 313129	



Limited Editions: TG reserves the right to offer glassware marked as "Limited Edition" in a certain amount and for a certain time period and under certain allocation criteria to Customer.

**R.Q. (RESTAURANT QUALITY) OF
HAND-MADE DECANTERS ONLY UPON AVAILABILITY.**



1756/14
AMADEO MINI
DECANTER







1405/14
TYROL MINI
DECANTER



1756/00
FATTO A MANO
AMADEO



1950/00
FATTO A MANO
MAMBA

ITEM	fine crystal hand-made		fine crystal hand-made		fine crystal hand-made		fine crystal hand-made	
	Item no.:	1756/14	Item no.:	1405/14	Item no.:	1756/00	Item no.:	1950/00
	Height/glass:	250 mm	Height/glass:	155 mm	Height/glass:	350 mm	Height/glass:	325 mm
	Capacity/glass:	750 ccm	Capacity/glass:	1090 ccm	Capacity/glass:	1500 ccm	Capacity/glass:	1500 ccm
	Design:	2019	Design:	2020	Design:	2017	Design:	2017
PACKAGING	Pieces/Bill unit:	1	Pieces/Bill unit:	1	Pieces/Bill unit:	1	Pieces/Bill unit:	1
TYPE AND QUANTITY	Bill units/MP:	1	Bill units/MP:	1	Bill units/MP:	1	Bill units/MP:	1
BILL UNIT DIMENSIONS	Length:	291 mm	Length:	172 mm	Length:	303 mm	Length:	420 mm
	Width:	198 mm	Width:	172 mm	Width:	183 mm	Width:	267 mm
	Height:	224 mm	Height:	476 mm	Height:	458 mm	Height:	435 mm
	Weight:	552 gr	Weight:	1004 gr	Weight:	1097 gr	Weight:	1412 gr
MASTERPACK DIMENSIONS	Length:	291 mm	Length:	177 mm	Length:	314 mm	Length:	425 mm
	Width:	198 mm	Width:	177 mm	Width:	194 mm	Width:	273 mm
	Height:	224 mm	Height:	477 mm	Height:	464 mm	Height:	445 mm
	Weight:	552 gr	Weight:	1135 gr	Weight:	1273 gr	Weight:	1772 gr
EURO PALLET	Bill units/pallet:	128	Bill units/pallet:	90	Bill units/pallet:	56	Bill units/pallet:	24
	Bill units/layer:	16	Bill units/layer:	9	Bill units/layer:	14	Bill units/layer:	6
	Layers/pallet:	8	Layers/pallet:	10	Layers/pallet:	4	Layers/pallet:	4
CONTAINER PALLET HIGH CUBE	Bill units/pallet:	224	Bill units/pallet:	182	Bill units/pallet:	100	Bill units/pallet:	45
	Bill units/layer:	28	Bill units/layer:	14	Bill units/layer:	20	Bill units/layer:	9
	Layers/pallet:	8	Layers/pallet:	13	Layers/pallet:	5	Layers/pallet:	5
EAN BILL UNIT	 9 006206 312979		 9 006206 320561		 9 006206 312795		 9 006206 312788	



Limited Editions: TG reserves the right to offer glassware marked as "Limited Edition" in a certain amount and for a certain time period and under certain allocation criteria to Customer.

DECANTER
HAND-MADE
FIRST QUALITY



1756/19
DECANTER
PERFORMANCE
AMADEO



2019/02
DECANTER
GIRAFE



2016/01
AYAM
CLEAR



2016/02
AYAM
BLACK STRIPE

ITEM	fine crystal hand-made		fine crystal hand-made		fine crystal hand-made		fine crystal hand-made	
	Item no.:		Item no.:		Item no.:		Item no.:	
	1756/19		2019/02		2016/01		2016/02	
	Height/glass:	350 mm	Height/glass:	325 mm	Height/glass:	287 mm	Height/glass:	287 mm
	Capacity/glass:	1500 ccm	Capacity/glass:	1130 ccm	Capacity/glass:	1700 ccm	Capacity/glass:	1700 ccm
	Design:	2019	Design:	2019	Design:	2016	Design:	2016
PACKAGING TYPE AND QUANTITY	Pieces/Bill unit:	1	Pieces/Bill unit:	1	Pieces/Bill unit:	1	Pieces/Bill unit:	1
	Bill units/MP:	1	Bill units/MP:	1	Bill units/MP:	1	Bill units/MP:	1
BILL UNIT DIMENSIONS	Length:	303 mm	Length:	279 mm	Length:	303 mm	Length:	303 mm
	Width:	183 mm	Width:	275 mm	Width:	183 mm	Width:	183 mm
	Height:	458 mm	Height:	551 mm	Height:	458 mm	Height:	458 mm
	Weight:	1097 gr	Weight:	1171 gr	Weight:	1147 gr	Weight:	1147 gr
MASTERPACK DIMENSIONS	Length:	314 mm	Length:	290 mm	Length:	314 mm	Length:	314 mm
	Width:	194 mm	Width:	281 mm	Width:	194 mm	Width:	194 mm
	Height:	464 mm	Height:	556 mm	Height:	464 mm	Height:	464 mm
	Weight:	1273 gr	Weight:	1390 gr	Weight:	1323 gr	Weight:	1323 gr
EURO PALLET	Bill units/pallet:	56	Bill units/pallet:	24	Bill units/pallet:	56	Bill units/pallet:	56
	Bill units/layer:	14	Bill units/layer:	4	Bill units/layer:	14	Bill units/layer:	14
	Layers/pallet:	4	Layers/pallet:	6	Layers/pallet:	4	Layers/pallet:	4
CONTAINER PALLET HIGH CUBE	Bill units/pallet:	100	Bill units/pallet:	48	Bill units/pallet:	100	Bill units/pallet:	100
	Bill units/layer:	20	Bill units/layer:	6	Bill units/layer:	20	Bill units/layer:	20
	Layers/pallet:	5	Layers/pallet:	8	Layers/pallet:	5	Layers/pallet:	5
EAN BILL UNIT								
	9 006206 313198		9 006206 313228		9 006206 312412		9 006206 312429	



**R.Q. (RESTAURANT QUALITY) OF
HAND-MADE DECANTERS ONLY UPON AVAILABILITY.**



1700/14
DUCK



2011/01
FLIRT



2016/14
AYAM MINI
DECANTER



2011/04 S1
CURLY CLEAR

ITEM	fine crystal hand-made		fine crystal hand-made		fine crystal hand-made		fine crystal hand-made	
	Item no.:	1700/14	Item no.:	2011/01	Item no.:	2016/14	Item no.:	2011/04 S1
	Height/glass:	130 mm	Height/glass:	350 mm	Height/glass:	230 mm	Height/glass:	265 mm
	Capacity/glass:	900 ccm	Capacity/glass:	1760 ccm	Capacity/glass:	810 ccm	Capacity/glass:	1400 ccm
	Design:	1998	Design:	2011	Design:	2019	Design:	2013
PACKAGING TYPE AND QUANTITY	Pieces/Bill unit:	1	Pieces/Bill unit:	1	Pieces/Bill unit:	1	Pieces/Bill unit:	1
	Bill units/MP:	1	Bill units/MP:	1	Bill units/MP:	1	Bill units/MP:	1
BILL UNIT DIMENSIONS	Length:	303 mm	Length:	279 mm	Length:	291 mm	Length:	303 mm
	Width:	183 mm	Width:	275 mm	Width:	198 mm	Width:	183 mm
	Height:	458 mm	Height:	551 mm	Height:	224 mm	Height:	458 mm
	Weight:	1357 gr	Weight:	1366 gr	Weight:	685 gr	Weight:	1047 gr
MASTERPACK DIMENSIONS	Length:	314 mm	Length:	290 mm	Length:	291 mm	Length:	314 mm
	Width:	194 mm	Width:	281 mm	Width:	198 mm	Width:	194 mm
	Height:	464 mm	Height:	556 mm	Height:	224 mm	Height:	464 mm
	Weight:	1533 gr	Weight:	1604 gr	Weight:	685 gr	Weight:	1223 gr
EURO PALLET	Bill units/pallet:	56	Bill units/pallet:	24	Bill units/pallet:	128	Bill units/pallet:	56
	Bill units/layer:	14	Bill units/layer:	4	Bill units/layer:	16	Bill units/layer:	14
	Layers/pallet:	4	Layers/pallet:	6	Layers/pallet:	8	Layers/pallet:	4
CONTAINER PALLET HIGH CUBE	Bill units/pallet:	100	Bill units/pallet:	48	Bill units/pallet:	224	Bill units/pallet:	100
	Bill units/layer:	20	Bill units/layer:	6	Bill units/layer:	28	Bill units/layer:	20
	Layers/pallet:	5	Layers/pallet:	8	Layers/pallet:	8	Layers/pallet:	5

EAN
BILL UNIT



Limited Editions: TG reserves the right to offer glassware marked as "Limited Edition" in a certain amount and for a certain time period and under certain allocation criteria to Customer.

DECANTER
HAND-MADE
FIRST QUALITY



2011/04
CURLY PINK



1925/01
SUPERLEGGERO



1977/26
CORNETTO
MAGNUM



2011/02
ESCARGOT

ITEM	fine crystal hand-made		fine crystal hand-made		fine crystal hand-made		fine crystal hand-made	
	Item no.:	2011/04	Item no.:	1925/01	Item no.:	1977/26	Item no.:	2011/02
	Height/glass:	265 mm	Height/glass:	410 mm	Height/glass:	425 mm	Height/glass:	150 mm
	Capacity/glass:	1400 ccm	Capacity/glass:	1585 ccm	Capacity/glass:	1850 ccm	Capacity/glass:	1400 ccm
	Design:	2013	Design:	2015	Design:	2003	Design:	2011
PACKAGING	Pieces/Bill unit:	1	Pieces/Bill unit:	1	Pieces/Bill unit:	1	Pieces/Bill unit:	1
TYPE AND QUANTITY	Bill units/MP:	1	Bill units/MP:	1	Bill units/MP:	1	Bill units/MP:	1
BILL UNIT DIMENSIONS	Length:	303 mm	Length:	172 mm	Length:	172 mm	Length:	303 mm
	Width:	183 mm	Width:	172 mm	Width:	172 mm	Width:	183 mm
	Height:	458 mm	Height:	476 mm	Height:	476 mm	Height:	458 mm
	Weight:	1047 gr	Weight:	960 gr	Weight:	960 gr	Weight:	1217 gr
MASTERPACK DIMENSIONS	Length:	314 mm	Length:	172 mm	Length:	172 mm	Length:	314 mm
	Width:	194 mm	Width:	172 mm	Width:	172 mm	Width:	194 mm
	Height:	464 mm	Height:	476 mm	Height:	476 mm	Height:	464 mm
	Weight:	1223 gr	Weight:	1091 gr	Weight:	1091 gr	Weight:	1393 gr
EURO PALLET	Bill units/pallet:	56	Bill units/pallet:	99	Bill units/pallet:	99	Bill units/pallet:	56
	Bill units/layer:	14	Bill units/layer:	9	Bill units/layer:	9	Bill units/layer:	14
	Layers/pallet:	4	Layers/pallet:	11	Layers/pallet:	11	Layers/pallet:	4
CONTAINER PALLET HIGH CUBE	Bill units/pallet:	100	Bill units/pallet:	182	Bill units/pallet:	182	Bill units/pallet:	100
	Bill units/layer:	20	Bill units/layer:	14	Bill units/layer:	14	Bill units/layer:	20
	Layers/pallet:	5	Layers/pallet:	13	Layers/pallet:	13	Layers/pallet:	5
EAN BILL UNIT								
	9 006206 213184		9 006206 312139		9 006206 311286		9 006206 311491	

**R.Q. (RESTAURANT QUALITY) OF
HAND-MADE DECANTERS ONLY UPON AVAILABILITY.**



1977/13 B
RIEDEL CORNETTO
CONFETTI DECANTER
BLUE







1977/13 G
RIEDEL CORNETTO
CONFETTI DECANTER
GREEN



1977/13 O
RIEDEL CORNETTO
CONFETTI DECANTER
ORANGE



1977/13 Y
RIEDEL CORNETTO
CONFETTI DECANTER
YELLOW

ITEM	fine crystal hand-made Item no.: 1977/13 B		fine crystal hand-made Item no.: 1977/13 G		fine crystal hand-made Item no.: 1977/13 O		fine crystal hand-made Item no.: 1977/13 Y	
	Height/glass:	325 mm	Height/glass:	325 mm	Height/glass:	325 mm	Height/glass:	325 mm
	Capacity/glass:	1200 ccm	Capacity/glass:	1200 ccm	Capacity/glass:	1200 ccm	Capacity/glass:	1200 ccm
	Design:	2020	Design:	2020	Design:	2020	Design:	2020
PACKAGING	Pieces/Bill unit:	1	Pieces/Bill unit:	1	Pieces/Bill unit:	1	Pieces/Bill unit:	1
TYPE AND QUANTITY	Bill units/MP:	4	Bill units/MP:	4	Bill units/MP:	4	Bill units/MP:	4
BILL UNIT DIMENSIONS	Length:	172 mm	Length:	172 mm	Length:	172 mm	Length:	172 mm
	Width:	172 mm	Width:	172 mm	Width:	172 mm	Width:	172 mm
	Height:	476 mm	Height:	476 mm	Height:	476 mm	Height:	476 mm
	Weight:	660 gr	Weight:	660 gr	Weight:	660 gr	Weight:	660 gr
MASTERPACK DIMENSIONS	Length:	177 mm	Length:	177 mm	Length:	177 mm	Length:	177 mm
	Width:	177 mm	Width:	177 mm	Width:	177 mm	Width:	177 mm
	Height:	477 mm	Height:	477 mm	Height:	477 mm	Height:	477 mm
	Weight:	791 gr	Weight:	791 gr	Weight:	791 gr	Weight:	791 gr
EURO PALLET	Bill units/pallet:	90	Bill units/pallet:	90	Bill units/pallet:	90	Bill units/pallet:	90
	Bill units/layer:	9	Bill units/layer:	9	Bill units/layer:	9	Bill units/layer:	9
	Layers/pallet:	10	Layers/pallet:	10	Layers/pallet:	10	Layers/pallet:	10
CONTAINER PALLET HIGH CUBE	Bill units/pallet:	182	Bill units/pallet:	182	Bill units/pallet:	182	Bill units/pallet:	182
	Bill units/layer:	14	Bill units/layer:	14	Bill units/layer:	14	Bill units/layer:	14
	Layers/pallet:	13	Layers/pallet:	13	Layers/pallet:	13	Layers/pallet:	13
EAN BILL UNIT	 9 006206 313709		 9 006206 313723		 9 006206 313730		 9 006206 313716	

DECANTER

DECANTER
HAND-MADE
FIRST QUALITY



1977/13 R
RIEDEL CORNETTO
CONFETTI DECANTER
RED



1977/13
CORNETTO
SINGLE



2009/04
BLACK TIE
OCCHIO NERO



2015/02
RIEDEL

ITEM	fine crystal hand-made		fine crystal hand-made		fine crystal hand-made		fine crystal hand-made	
	Item no.:	1977/13 R	Item no.:	1977/13	Item no.:	2009/04	Item no.:	2015/02
	Height/glass:	325 mm	Height/glass:	325 mm	Height/glass:	365 mm	Height/glass:	365 mm
	Capacity/glass:	1200 ccm	Capacity/glass:	1200 ccm	Capacity/glass:	1210 ccm	Capacity/glass:	1210 ccm
	Design:	2020	Design:	2003	Design:	2010	Design:	2015
PACKAGING	Pieces/Bill unit:	1	Pieces/Bill unit:	1	Pieces/Bill unit:	1	Pieces/Bill unit:	1
TYPE AND QUANTITY	Bill units/MP:	4	Bill units/MP:	1	Bill units/MP:	1	Bill units/MP:	1
BILL UNIT	Length:	172 mm	Length:	172 mm	Length:	172 mm	Length:	172 mm
DIMENSIONS	Width:	172 mm	Width:	172 mm	Width:	172 mm	Width:	172 mm
	Height:	476 mm	Height:	476 mm	Height:	476 mm	Height:	476 mm
	Weight:	660 gr	Weight:	660 gr	Weight:	990 gr	Weight:	990 gr
MASTERPACK	Length:	177 mm	Length:	172 mm	Length:	177 mm	Length:	177 mm
DIMENSIONS	Width:	177 mm	Width:	172 mm	Width:	177 mm	Width:	177 mm
	Height:	477 mm	Height:	476 mm	Height:	477 mm	Height:	477 mm
	Weight:	791 gr	Weight:	791 gr	Weight:	1121 gr	Weight:	1121 gr
EURO PALLET	Bill units/pallet:	90	Bill units/pallet:	192	Bill units/pallet:	90	Bill units/pallet:	90
	Bill units/layer:	9	Bill units/layer:	16	Bill units/layer:	9	Bill units/layer:	9
	Layers/pallet:	10	Layers/pallet:	12	Layers/pallet:	10	Layers/pallet:	10
CONTAINER PALLET	Bill units/pallet:	182	Bill units/pallet:	182	Bill units/pallet:	182	Bill units/pallet:	182
HIGH CUBE	Bill units/layer:	14	Bill units/layer:	14	Bill units/layer:	14	Bill units/layer:	14
	Layers/pallet:	13	Layers/pallet:	13	Layers/pallet:	13	Layers/pallet:	13
EAN								
BILL UNIT	9 006206 313693		9 006206 311279		9 006206 213085		9 006206 312153	

**R.Q. (RESTAURANT QUALITY) OF
HAND-MADE DECANTERS ONLY UPON AVAILABILITY.**



2009/01
BLACK TIE
SMILE





2011/14
CURLY MINI
DECANTER



1977/00
FATTO A MANO
CORNETTO



2011/00
FATTO A MANO
CURLY

ITEM	fine crystal hand-made		fine crystal hand-made		fine crystal hand-made		fine crystal hand-made	
	Item no.:	2009/01	Item no.:	2011/14	Item no.:	1977/00	Item no.:	2011/00
	Height/glass:	365 mm	Height/glass:	183 mm	Height/glass:	325 mm	Height/glass:	265 mm
	Capacity/glass:	1410 ccm	Capacity/glass:	690 ccm	Capacity/glass:	1200 ccm	Capacity/glass:	1400 ccm
	Design:	2010	Design:	2019	Design:	2017	Design:	2018
PACKAGING	Pieces/Bill unit:	1	Pieces/Bill unit:	1	Pieces/Bill unit:	1	Pieces/Bill unit:	1
TYPE AND QUANTITY	Bill units/MP:	1	Bill units/MP:	1	Bill units/MP:	1	Bill units/MP:	1
BILL UNIT DIMENSIONS	Length:	172 mm	Length:	291 mm	Length:	172 mm	Length:	303 mm
	Width:	172 mm	Width:	198 mm	Width:	172 mm	Width:	183 mm
	Height:	476 mm	Height:	224 mm	Height:	476 mm	Height:	458 mm
	Weight:	1000 gr	Weight:	579 gr	Weight:	713 gr	Weight:	1047 gr
MASTERPACK DIMENSIONS	Length:	177 mm	Length:	291 mm	Length:	172 mm	Length:	314 mm
	Width:	177 mm	Width:	198 mm	Width:	172 mm	Width:	194 mm
	Height:	477 mm	Height:	224 mm	Height:	476 mm	Height:	464 mm
	Weight:	1131 gr	Weight:	579 gr	Weight:	844 gr	Weight:	1223 gr
EURO PALLET	Bill units/pallet:	90	Bill units/pallet:	128	Bill units/pallet:	192	Bill units/pallet:	56
	Bill units/layer:	9	Bill units/layer:	16	Bill units/layer:	16	Bill units/layer:	14
	Layers/pallet:	10	Layers/pallet:	8	Layers/pallet:	12	Layers/pallet:	4
CONTAINER PALLET HIGH CUBE	Bill units/pallet:	182	Bill units/pallet:	224	Bill units/pallet:	182	Bill units/pallet:	100
	Bill units/layer:	14	Bill units/layer:	28	Bill units/layer:	14	Bill units/layer:	20
	Layers/pallet:	13	Layers/pallet:	8	Layers/pallet:	13	Layers/pallet:	5
EAN BILL UNIT	 9 006206 212934		 9 006206 313235		 9 006206 312801		 9 006206 312924	



Limited Editions: TG reserves the right to offer glassware marked as "Limited Edition" in a certain amount and for a certain time period and under certain allocation criteria to Customer.

DECANTER
HAND-MADE
FIRST QUALITY



1414/26
O MAGNUM



2400/13
ULTRA MAGNUM



2009/02
BLACK TIE
TOUCH



2009/03
BLACK TIE
BLISS

ITEM	fine crystal hand-made		fine crystal hand-made		fine crystal hand-made		fine crystal hand-made	
	Item no.:	1414/26	Item no.:	2400/13	Item no.:	2009/02	Item no.:	2009/03
	Height/glass:	385 mm	Height/glass:	240 mm	Height/glass:	365 mm	Height/glass:	365 mm
	Capacity/glass:	2300 ccm	Capacity/glass:	2000 ccm	Capacity/glass:	1430 ccm	Capacity/glass:	1210 ccm
	Design:	2005	Design:	1994	Design:	2010	Design:	2010
PACKAGING	Pieces/Bill unit:	1	Pieces/Bill unit:	1	Pieces/Bill unit:	1	Pieces/Bill unit:	1
TYPE AND QUANTITY	Bill units/MP:	1	Bill units/MP:	1	Bill units/MP:	1	Bill units/MP:	1
BILL UNIT DIMENSIONS	Length:	172 mm	Length:	290 mm	Length:	172 mm	Length:	172 mm
	Width:	172 mm	Width:	290 mm	Width:	172 mm	Width:	172 mm
	Height:	476 mm	Height:	308 mm	Height:	476 mm	Height:	476 mm
	Weight:	1050 gr	Weight:	1301 gr	Weight:	990 gr	Weight:	990 gr
MASTERPACK DIMENSIONS	Length:	177 mm	Length:	299 mm	Length:	177 mm	Length:	177 mm
	Width:	177 mm	Width:	299 mm	Width:	177 mm	Width:	177 mm
	Height:	477 mm	Height:	314 mm	Height:	477 mm	Height:	477 mm
	Weight:	1181 gr	Weight:	1440 gr	Weight:	1121 gr	Weight:	1121 gr
EURO PALLET	Bill units/pallet:	90	Bill units/pallet:	48	Bill units/pallet:	90	Bill units/pallet:	90
	Bill units/layer:	9	Bill units/layer:	8	Bill units/layer:	9	Bill units/layer:	9
	Layers/pallet:	10	Layers/pallet:	6	Layers/pallet:	10	Layers/pallet:	10
CONTAINER PALLET HIGH CUBE	Bill units/pallet:	182	Bill units/pallet:	84	Bill units/pallet:	182	Bill units/pallet:	182
	Bill units/layer:	14	Bill units/layer:	12	Bill units/layer:	14	Bill units/layer:	14
	Layers/pallet:	13	Layers/pallet:	7	Layers/pallet:	13	Layers/pallet:	13
EAN BILL UNIT	 9 006206 311316		 9 006206 310036		 9 006206 212941		 9 006206 212968	

**R.Q. (RESTAURANT QUALITY) OF
HAND-MADE DECANTERS ONLY UPON AVAILABILITY.**



2009/01 S3
BLACK TIE
SMILE RED







2009/02 S3
BLACK TIE
TOUCH RED



2009/03 S3
BLACK TIE
BLISS RED



1977/14
CORNETTO MINI
DECANTER

ITEM	fine crystal hand-made		fine crystal hand-made		fine crystal hand-made		fine crystal hand-made	
	Item no.:	2009/01 S3	Item no.:	2009/02 S3	Item no.:	2009/03 S3	Item no.:	1977/14
	Height/glass:	365 mm	Height/glass:	365 mm	Height/glass:	365 mm	Height/glass:	282 mm
	Capacity/glass:	1410 ccm	Capacity/glass:	1430 ccm	Capacity/glass:	1210 ccm	Capacity/glass:	720 ccm
	Design:	2010	Design:	2010	Design:	2010	Design:	2019
PACKAGING TYPE AND QUANTITY	Pieces/Bill unit:	1	Pieces/Bill unit:	1	Pieces/Bill unit:	1	Pieces/Bill unit:	1
	Bill units/MP:	1	Bill units/MP:	1	Bill units/MP:	1	Bill units/MP:	1
BILL UNIT DIMENSIONS	Length:	172 mm	Length:	172 mm	Length:	172 mm	Length:	291 mm
	Width:	172 mm	Width:	172 mm	Width:	172 mm	Width:	198 mm
	Height:	476 mm	Height:	476 mm	Height:	476 mm	Height:	224 mm
	Weight:	1000 gr	Weight:	990 gr	Weight:	990 gr	Weight:	625 gr
MASTERPACK DIMENSIONS	Length:	177 mm	Length:	177 mm	Length:	177 mm	Length:	291 mm
	Width:	177 mm	Width:	177 mm	Width:	177 mm	Width:	198 mm
	Height:	477 mm	Height:	477 mm	Height:	477 mm	Height:	224 mm
	Weight:	1131 gr	Weight:	1121 gr	Weight:	1121 gr	Weight:	625 gr
EURO PALLET	Bill units/pallet:	90	Bill units/pallet:	90	Bill units/pallet:	90	Bill units/pallet:	128
	Bill units/layer:	9	Bill units/layer:	9	Bill units/layer:	9	Bill units/layer:	16
	Layers/pallet:	10	Layers/pallet:	10	Layers/pallet:	10	Layers/pallet:	8
CONTAINER PALLET HIGH CUBE	Bill units/pallet:	182	Bill units/pallet:	182	Bill units/pallet:	182	Bill units/pallet:	224
	Bill units/layer:	14	Bill units/layer:	14	Bill units/layer:	14	Bill units/layer:	28
	Layers/pallet:	13	Layers/pallet:	13	Layers/pallet:	13	Layers/pallet:	8
EAN BILL UNIT	 9 006206 212983		 9 006206 213016		 9 006206 213047		 9 006206 313112	



Limited Editions: TG reserves the right to offer glassware marked as "Limited Edition" in a certain amount and for a certain time period and under certain allocation criteria to Customer.

DECANTER
HAND-MADE
FIRST QUALITY



2400/14
ULTRA



1414/13
O SINGLE



2019/03
DECANTER
MOSEL



2019/04
DECANTER
MEDOC

ITEM	fine crystal hand-made		fine crystal hand-made		fine crystal hand-made		fine crystal hand-made	
	Item no.:	2400/14	Item no.:	1414/13	Item no.:	2019/03	Item no.:	2019/04
	Height/glass:	225 mm	Height/glass:	225 mm	Height/glass:	290 mm	Height/glass:	290 mm
	Capacity/glass:	1230 ccm	Capacity/glass:	980 ccm	Capacity/glass:	1150 ccm	Capacity/glass:	1110 ccm
	Design:	1994	Design:	2006	Design:	2019	Design:	2019
PACKAGING TYPE AND QUANTITY	Pieces/Bill unit:	1	Pieces/Bill unit:	1	Pieces/Bill unit:	1	Pieces/Bill unit:	1
	Bill units/MP:	1	Bill units/MP:	1	Bill units/MP:	1	Bill units/MP:	1
BILL UNIT DIMENSIONS	Length:	290 mm	Length:	290 mm	Length:	172 mm	Length:	172 mm
	Width:	290 mm	Width:	130 mm	Width:	172 mm	Width:	172 mm
	Height:	308 mm	Height:	130 mm	Height:	476 mm	Height:	476 mm
	Weight:	1101 gr	Weight:	595 gr	Weight:	842 gr	Weight:	845 gr
MASTERPACK DIMENSIONS	Length:	299 mm	Length:	290 mm	Length:	177 mm	Length:	177 mm
	Width:	299 mm	Width:	130 mm	Width:	177 mm	Width:	177 mm
	Height:	314 mm	Height:	130 mm	Height:	477 mm	Height:	477 mm
	Weight:	1240 gr	Weight:	595 gr	Weight:	973 gr	Weight:	976 gr
EURO PALLET	Bill units/pallet:	48	Bill units/pallet:	280	Bill units/pallet:	90	Bill units/pallet:	90
	Bill units/layer:	8	Bill units/layer:	20	Bill units/layer:	9	Bill units/layer:	9
	Layers/pallet:	6	Layers/pallet:	14	Layers/pallet:	10	Layers/pallet:	10
CONTAINER PALLET HIGH CUBE	Bill units/pallet:	84	Bill units/pallet:	527	Bill units/pallet:	182	Bill units/pallet:	182
	Bill units/layer:	12	Bill units/layer:	31	Bill units/layer:	14	Bill units/layer:	14
	Layers/pallet:	7	Layers/pallet:	17	Layers/pallet:	13	Layers/pallet:	13
EAN BILL UNIT	 9 006206 310920		 9 006206 311293		 9 006206 313266		 9 006206 313273	

**R.Q. (RESTAURANT QUALITY) OF
HAND-MADE DECANTERS ONLY UPON AVAILABILITY.**



2017/01
MACON



2017/02
MARNE



2017/03
MARGAUX



2400/15
ULTRA MINI
DECANTER

ITEM	fine crystal hand-made		fine crystal hand-made		fine crystal hand-made		fine crystal hand-made	
	Item no.:	2017/01	Item no.:	2017/02	Item no.:	2017/01	Item no.:	2400/15
	Height/glass:	210 mm	Height/glass:	200 mm	Height/glass:	153 mm	Height/glass:	157 mm
	Capacity/glass:	1425 ccm	Capacity/glass:	1894 ccm	Capacity/glass:	1425 ccm	Capacity/glass:	680 ccm
	Design:	2017	Design:	2017	Design:	2017	Design:	2020
PACKAGING	Pieces/Bill unit:	1	Pieces/Bill unit:	1	Pieces/Bill unit:	1	Pieces/Bill unit:	1
TYPE AND QUANTITY	Bill units/MP:	1	Bill units/MP:	1	Bill units/MP:	1	Bill units/MP:	1
BILL UNIT DIMENSIONS	Length:	260 mm	Length:	260 mm	Length:	260 mm	Length:	291 mm
	Width:	260 mm	Width:	260 mm	Width:	260 mm	Width:	198 mm
	Height:	240 mm	Height:	240 mm	Height:	240 mm	Height:	224 mm
	Weight:	668 gr	Weight:	668 gr	Weight:	668 gr	Weight:	762 gr
MASTERPACK DIMENSIONS	Length:	266 mm	Length:	266 mm	Length:	266 mm	Length:	291 mm
	Width:	266 mm	Width:	266 mm	Width:	266 mm	Width:	198 mm
	Height:	244 mm	Height:	244 mm	Height:	244 mm	Height:	224 mm
	Weight:	883 gr	Weight:	883 gr	Weight:	883 gr	Weight:	762 gr
EURO PALLET	Bill units/pallet:	84	Bill units/pallet:	84	Bill units/pallet:	84	Bill units/pallet:	128
	Bill units/layer:	12	Bill units/layer:	12	Bill units/layer:	12	Bill units/layer:	16
	Layers/pallet:	7	Layers/pallet:	7	Layers/pallet:	7	Layers/pallet:	8
CONTAINER PALLET HIGH CUBE	Bill units/pallet:	144	Bill units/pallet:	144	Bill units/pallet:	144	Bill units/pallet:	224
	Bill units/layer:	16	Bill units/layer:	16	Bill units/layer:	16	Bill units/layer:	28
	Layers/pallet:	9	Layers/pallet:	9	Layers/pallet:	9	Layers/pallet:	8
EAN BILL UNIT	 9 006206 312733		 9 006206 312740		 9 006206 312757		 9 006206 320578	



1. ADDITIONAL COSTS FOR CUSTOMERS CALIBRATION AND POUR AID

- No stock production. Manufacturing after fix order.
- Minimum order quantity 120 pieces per glass size (for re-orders as well).
- A quantity +/- 10% compared to the order quantity has to be accepted by the client.

The following prices are given for special calibrations and pour aid as per the German Calibration Act, if they are not included in the collection according to the price list:

prices per piece and per glass size orders exceeding: (Single marks / Double marks)	120 pcs.	600 pcs.	2500 pcs.
machine blown glass	€ 0.60	€ 0.50	on request

**PLEASE NOTE: CE mark can also be applied on the base (two work steps).
Further information on request.¹**

prices per piece and per glass size orders exceeding:	120 pcs.	600 pcs.	2500 pcs.
machine blown glass	€ 0.90	€ 0.75	€ 0.45

2. SIGNETS & VIGNETTES - SILK SCREEN PRINTING (WITHOUT CALIBRATION AND POUR AID)

- On bowl only.
- No stock production. Manufacturing after fix order.
- Minimum order quantity 60 pieces per glass size (for re-orders as well).
- A quantity +/- 10% compared to the order quantity has to be accepted by the client.

For the first production you have to pay non-recurring tool costs of Euro 150.- if you have a appropriate artwork. If we have to re-produce the artwork we have to charge approx Euro 300.- May we ask you to send us your artwork in order or us to determine the appropriate technique to execute your vignette. Silk screen printing costs for Gold and Platinum upon request.

Pieces	prices per piece and per glass size orders exceeding: For stem glasses, machine made Color: matt white
60 pcs.	€ 2.99
120 pcs.	€ 1.99
240 pcs.	€ 1.21
300 pcs.	€ 1.04
420 pcs.	€ 0.93
540 pcs.	€ 0.72
1.200 pcs.	€ 0.47
2.500 pcs.	€ 0.42
5.000 pcs.	€ 0.32
10.000 pcs.	€ 0.26



SINGLE POUR LINE



DOUBLE POUR LINE



SEPARATE PROCESS

3. SIGNETS & VIGNETTES - SILK SCREEN PRINTING (INCLUDING CALIBRATION AND POUR AID)

- No stock production. Manufacturing after fix order.
- Minimum order quantity 120 pieces per glass size (for re-orders as well).
- A quantity +/- 10% compared to the order quantity has to be accepted by the client.

prices per piece and per glass size orders exceeding:	120 pcs.	240 pcs.	600 pcs.	2500 pcs.
For stem glasses, machine made Color: matt white	€ 2.09	€ 1.29	€ 0.79	on request

For the first production you have to pay a one time tool costs of Euro 150,- you have the appropriate artwork. If we have to re-produce the artwork we have to charge approx Euro 300,-. May we ask you to send us your artwork in order to determine the appropriate technique to execute your vignette. Silk screen printing costs for Gold and Platinum upon request.

4. INFORMATION ABOUT SILK SCREEN DECORATION:

In decorating glass with the screen printing process, colour is pressed through a silk screen to the glass surface and fixed to the glass during a temperature treatment. The colours, used by RIEDEL, are organic colours without heavy metals (such as lead, barium, etc.) or other toxic components. These colours have a high dishwasher resistance, but compared with ceramic colours a lower mechanical resistance.

5. ATTENTION:

The water hardness for cleaning glass, should not be less than 3° d.H.

Glasses with organic colours should be placed in the dishwasher in a way that they cannot make contact with each other during the washing process. If cleaning the glasses by hand, please do not use a scouring brush or abrasive detergents.

Be aware that fully desalinated water is extremely aggressive to both the glass surface and screen print decoration.

Over/underproduction (+10/-10 %) may be possible and will be billed accordingly.



SEPARATE
PROCESS



Microfiber Polishing Cloth

- Wash at boiling temperature (to kill bacteria) with odorless soap
- Should be machine washed at min. 170° F/75° C
- Never use fabric softener when rinsing your microfiber polishing cloth (avoids grease film on surface)

Caring for your Riedel Crystal

- Riedel glasses are dishwasher safe
- To avoid scratches: Avoid glass contact with other glass or metal
- If available use a stemware rack
- To avoid stains: use soft water (low mineral content)
- To remove stains: use white vinegar

If washing by hand

- Wash the glass under warm water (use detergent and rinse the glass carefully)
- Glass polishing: Use two polishing cloths, never hold the glass by the base to polish the bowl
- Stem snap: Occurs through mishandling = torque or bend pressure at the stem
- Storage: Avoid glass storage in kitchen cabinets which have strong aromas that translates into glass

For a perfect result

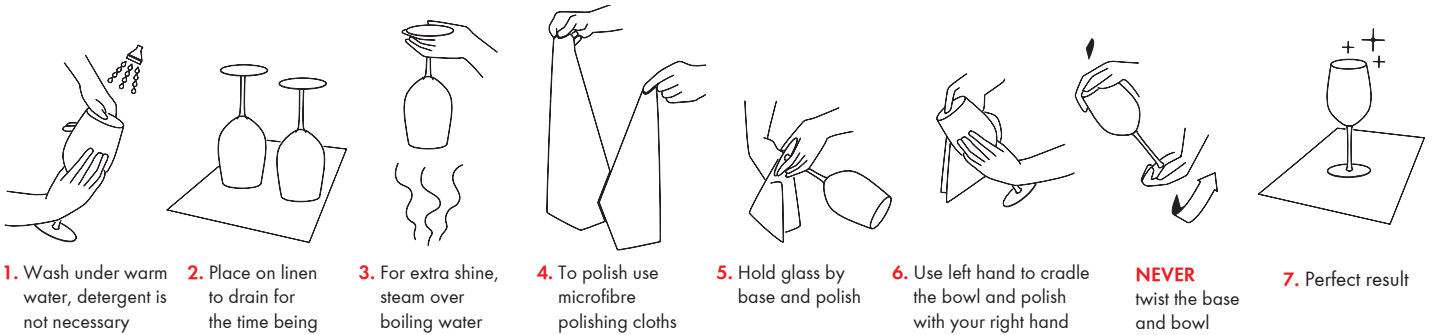

1. Wash under warm water, detergent is not necessary
2. Place on linen to drain for the time being
3. For extra shine, steam over boiling water
4. To polish use microfibre polishing cloths
5. Hold glass by base and polish
6. Use left hand to cradle the bowl and polish with your right hand
- NEVER** twist the base and bowl
7. Perfect result

CAUTION: A Riedel glass is a grape varietal specific wine tool! This shape works best with wines made from specific grapes. Please read the instructions below to guarantee maximum enjoyment. Riedel has researched the

grape varietal sensation, leading to the conclusion, on which the world's wine experts agree; that the enjoyment of aroma, taste, texture and finish of a wine, is maximized by using the right "WINE TOOL"



Rules when handling connoisseur glasses



1 Filling the glass

Fill the glass only to the widest diameter of its bowl. This will ensure maximum development of the wine's bouquet, and also provide the most elegant table setting.



2 Holding the glass

The appropriately filled glass should always be held by the stem rather than the bowl, as heat from the hand could raise the temperature above its optimum and negatively influence the bouquet of the wine.



3 Swirling the glass

Carefully swirling the glass allows oxygen into the wine by increasing its surface area and helps release the wine's rich, mature aroma.



4 Why and how to decant wines

To decant wine means to transfer it from its bottle to a decanter or carafe before drinking. During storage or aging, wine can develop a solid deposit or sediment at the bottom of the bottle. Decanting is an easy means of separating the sediment from the wine. It also helps the wine breathe, as the greater surface diameter lets more oxygen reach the wine than the bottle does. Red wines should be decanted well before serving and allowed to rest at room temperature for up to one hour to allow the wine to fully develop its bouquet.



5 Wine temperature

Before decanting/or serving wine, store it at appropriate temperatures (red wine 59-63°F, 15-17°C, white wines at 50-54°F, 10-12°C). The proper serving temperature enhances the quality of the wine by allowing it to fully develop its characteristic aromas and flavours.



The RIEDEL TRADEMARK dates from the Art Nouveau period at the end of the nineteenth century, and was used for RIEDEL glassware made in Bohemia from 1890 to 1925. In 1996, to commemorate RIEDEL'S 240th anniversary, we reintroduced this trademark for all our hand-made and hand-finished products. The distinctive Riedel signature is now featured on the base of all these products. This signature trademark (1) helps our customers to distinguish immediately between hand-made, hand-finished products and those made by machine (2). Our machine-made products carry this trademark. The RIEDEL glass dynasty is built on the creative energies of a long line of glassmakers. The story begins in 1756 in Bohemia and continues right down to the united Europe of today, taking in on the way some of the most dramatic events in European history.

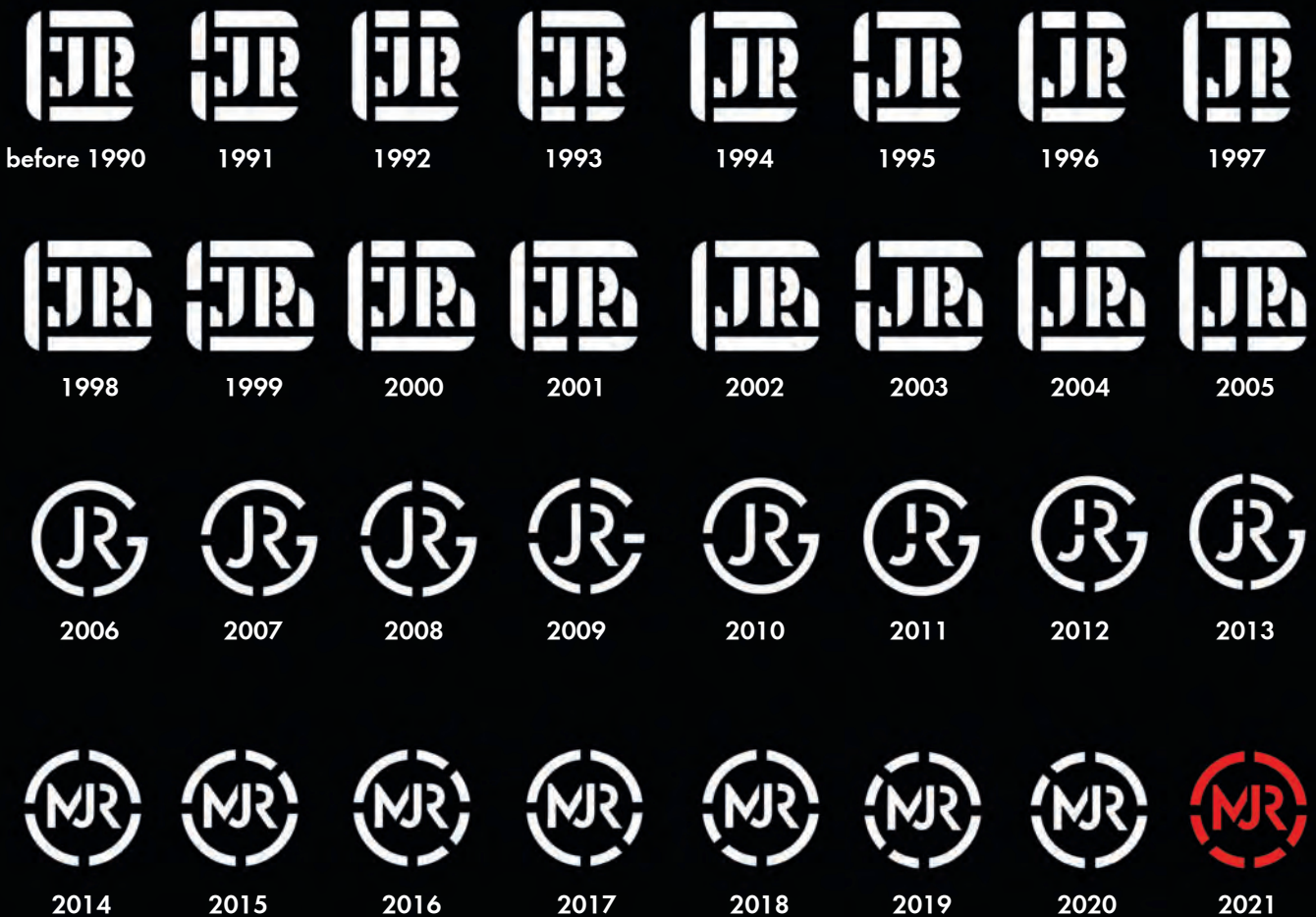



MAXIMILIAN J. RIEDEL
11TH GENERATION



GO GREEN - SUSTAINABILITY

Our Glassware

- Durable / sustainable product - long lasting and reusable for many years
- Up to 50% made from recycled Riedel crystal within our factories
- Crystal-Glass is inert and does not react with substances or materials that it comes into contact with (in contrast to plastic which, for example, can release Bisphenol A (BPA))
- Production processes are completely BPA-free / no plastic
- Our crystal glass is compliant with all known migration limits and is fully certified for safe usage with food and drinks
- 100% recyclable

Our Packaging



- Green Dot certified (production sites Germany - the company is committed to recovery and recycling)
- 45% FSC® - Forest Stewardship Council
- Reclay whole system (production sites Austria)
- Recyclable
- We work with sustainability-committed suppliers only. For example, with Mondi RIEDEL has won a Sustainability Award for the jointly developed packaging solution from Riedel Performance

Our Factories



- Implemented environment certificates ISO 14001: 2015 and ISO 50001: 2011
- Main raw materials are locally sourced e.g. quartz sand from Hirschau (short transport routes)
- Energy-saving projects include: compressed air, burner technology, energy efficient drives, LED lighting, waste heat recovery, water saving measures
- Substitution of hazardous substances with more environmentally friendly options

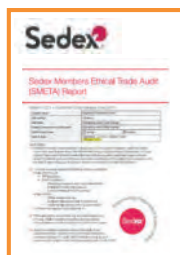

www.riedel.com

HAND-MADE ITEMS

FOR COLOURED DECANTERS:

- a minimum order of 10 decanters
- all handmade decanters can be customized BUT limited edition colours can not be used, also metal colours like gold are not available
- No samples will be sent prior, note that colours cannot be predicted due to the fact, that this is depending on how thin the glass is blown.
- 50% Pre-payment applies.
- For customized items, Riedel would ask that customers be amenable to accepting an over or under production of 20 %.

Exception: Face to Face

- minimum order 10 pieces **WITHOUT** any upcharge.
- Process: please provide profile image, we will than do a drawing which has to be approved by the customer prior production.
- No samples will be available prior production.
- All customized items are excluded from promotions.



BLACK TIE
FACE TO FACE
4100/13



EVE
1950/09-S7

FOR CUSTOMIZED STEMWARE:

- Minimum order quantity: 150 pcs.
- 50% Pre-payment applies.
- Fatto A Mano only 2 colours.



CUSTOMIZED ,OCCHIO NERO' DECANTER

Pre-Arrangements

- Before order can be confirmed we need to get the logo from the customer in order to enable us to check whether it is feasible from a technical point of view.
- The line width must at least 2 mm at all parts of the logo.
- 50% Pre-payment applies.

Sampling

- Even if only one single sample is required we need a high quality stamp as per attached picture, therefore we have to charge € 500,- for the sample.
- Sample has to be approved by the customer.

Basic parameters for orders

- Minimum order quantity: 50 pcs
- For customized items, Riedel would ask that customers be amenable to accepting an over or under production of 10 %.



BLACK TIE
OCCHIO NERO
2009/04

Offer valid for alteration of logo etc. within the elliptical-shaped dent, variations of shape of dent have to be quoted separately.



Example for stamp

Embossing is possible in 3 basic shapes:

- 1 Circle of 60 mm
- 2 Small oval of 69 x 41 mm
- 3 Large oval of 76 x 50 mm

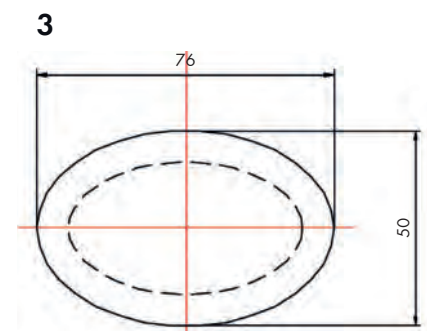
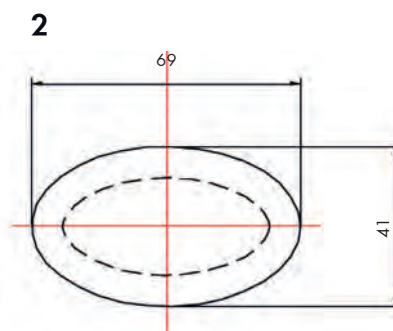
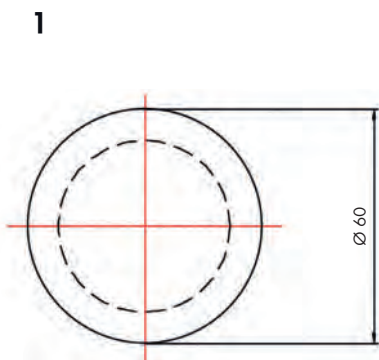

RIEDEL

„sensory“
work shop

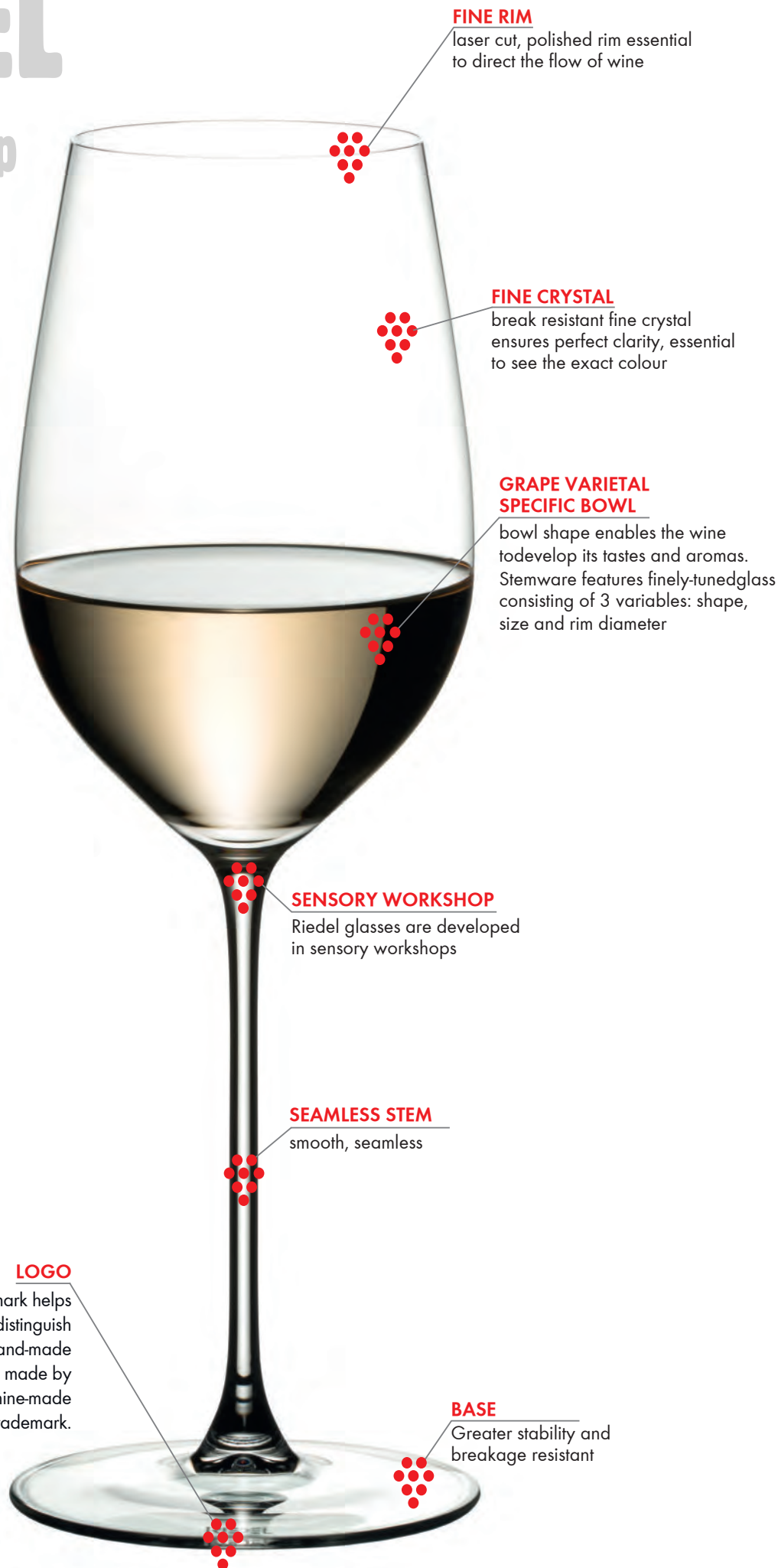

FINE RIM

laser cut, polished rim essential to direct the flow of wine

FINE CRYSTAL

break resistant fine crystal ensures perfect clarity, essential to see the exact colour

GRAPE VARIETAL SPECIFIC BOWL

bowl shape enables the wine to develop its tastes and aromas. Stemware features finely-tuned glass consisting of 3 variables: shape, size and rim diameter

SENSORY WORKSHOP

Riedel glasses are developed in sensory workshops

SEAMLESS STEM

smooth, seamless

LOGO

This *Riedel* signature trademark helps our customers to distinguish immediately between hand-made products and those made by machine. Our machine-made products carry this **RIEDEL** trademark.

BASE

Greater stability and breakage resistant

GENERAL TERMS AND CONDITIONS OF CONTRACT OF TIROLER GLASHÜTTE GMBH 2021 ("TG").

1. SCOPE OF APPLICATION.

All provisions of goods and services by Tiroler Glashütte GmbH ("TG") to or for the benefit of each customer (the "Customer") of TG shall be subject to the following General Terms and Conditions of Contract (the "T&C"), unless otherwise expressly agreed upon in writing duly signed by TG. Any and all terms and conditions of Customer, whether memorialized via written statement, purchase order, or otherwise, shall not be binding upon TG unless such terms and conditions are duly acknowledged and expressly agreed to in writing and signed by TG. By ordering products sold by TG (the "Products"), Customer will be deemed to have acknowledged and agreed to, and further be bound by these T&C, regardless of whether Customer signs or otherwise acknowledges its agreement to be bound by these T&C in writing or otherwise. For the avoidance of doubt, the acceptance of orders or performance of services by TG may not be regarded as the grant of any entitlement to future fulfillment of orders or provision of services by TG, and nothing in these T&C shall be construed as creating a relationship of exclusivity between Customer and TG.

2. ORDERS.

2.1. All orders by Customer (the "Orders", or each an "Order") shall become legally effective and binding on Customer upon written acceptance by TG of each such Order (an "Order Confirmation") or, in the absence of such Order Confirmation, by delivery of the Products comprising such Order to Customer. Customer may modify any Order at any time before TG's delivery to Customer of the Order Confirmation for such Order, but under no circumstances shall Customer be permitted to modify any Order more than five (5) calendar days after placing such Order. TG will communicate expected lead-times of Products in the respective Order Confirmation (in this context see Clause 6.4).

2.2. Once an Order is confirmed by TG or delivered to Customer, such Order may not be cancelled by Customer except with the prior consent in writing of TG, in which case Customer shall indemnify TG against all losses (including indirect and consequential losses) under or in connection with such cancellation.

2.3. TG reserves the right to (i) reject any Order at any time without giving any reasons, (ii) accept Orders only with respect to amounts that from experience correspond to usual quantities ordered by companies of a comparable size/type like Customer's company and/or to (iii) terminate any framework agreement possibly existing at any time with immediate effect without giving any reasons.

2.4. Customer shall comply on all its Orders with all guidelines communicated by TG regarding minimum Order values and minimum Product Orders, including those set out in these T&C.

2.5. Special Orders: Orders for any Products not featured in the applicable Price Books ("Special Orders") require a 50% deposit. Special Orders can be combined with any other Orders to meet Order minimums. Quantities of Special Orders can only be ordered in full master packs. No returns or cancellations on Special Orders are permitted.

2.6. Value Packs: Any preferential conditions on which Customers may purchase packs containing free Products ("Value Packs") must - to the extent legally permissible - be passed on to the end-consumer in at least the same amount. The Customer may not unpack Value Packs and may not sell any merchandise included in Value Packs individually.

2.7. Limited Editions: TG reserves the right to offer Products marked as "Limited Edition" in a certain amount and for a certain time period and under certain allocation criteria to Customer.

2.8. Glassware marked as "On-Premise Glass Collection/Glassware" is reserved for the hospitality industry only, and is not intended for resale, the retail trade and/or for end-consumers.

2.9. Customer acknowledges that the packaging and labeling of the Products as designed and implemented by TG is critical to maintain the Brand (as defined in Clause 3.2.) recognition and image of the respective Brands. Without the prior written consent of TG, Customer shall not modify or remove or otherwise make illegible or unreadable any packaging, labeling, markings or other items, such as promotional materials or instructions, howsoever affixed to the Products themselves or their packaging or accompanying the Products as shipped to Customer. The Products shall not be unpacked from their original packaging as shipped to Customer or be repacked by Customer but shall be sold by Customer in its original packaging, unless first expressly authorized by TG in writing. In the event that TG duly grants Customer the right to repack or unpackage Products (collectively, "Authorized Packaging Changes"), Customer shall ensure that the repackaged or unpackage Products and the packaging used by Customer (the "Customer Packaging") comply with all applicable laws, rules, and regulations, including but not limited to those laws, rules, and regulations that concern such Products' and Customer Packagings' labeling, packaging, marketing, storage,

distribution, and sale, and Customer shall indemnify, defend, and hold harmless TG for any violations or alleged violations thereof.

TG and its affiliates shall not be responsible for, and Customer shall indemnify, defend and hold TG harmless from, and against, any and all claims, suits, losses, damages, demands, injuries, costs and expenses (including reasonable attorney's fees and legal fees) arising out of or related to Authorized Packaging Changes to Products, including but not limited to any damage or loss arising out of the Product's labelling, packaging, marketing, storage, distribution, and/or sale.

In the event that Customer elects to purchase TG's Product comprising two wine glasses within packaging permitting Customer's inclusion of one bottle of wine (the "2 Glasses 1 Bottle Product"), Customer shall ensure that the 2 Glasses 1 Bottle Product complies with all applicable laws, rules, and regulations, including but not limited to those laws, rules, and regulations that concern such 2 Glasses 1 Bottle Product's labeling, packaging, marketing, storage, distribution, and sale, and Customer shall indemnify, defend, and hold harmless TG for any violations or alleged violations thereof.

2.10. TG does not provide Customers with any kind of marketing support, unless decided by TG in its sole discretion on an individual case-by-case basis. In the event that TG elects to grant any kind of marketing support to Customer, under no circumstances shall TG be obligated to complete or otherwise continue such marketing support or provide any future marketing support. Under no circumstances shall Customer be entitled to reimbursement for investments, promotional events, or promotional material of any kind whatsoever regarding the Brands (as defined in Clause 3.2.), irrespectively if Customer purchased such material from TG or from a third party.

3. CUSTOMER OBLIGATIONS.

Customer hereby agrees to at all times observe and abide by the obligations (the "Customer Obligations") as outlined in this Clause 3 of these T&C.

3.1. Retail Customers may sell retail Products received from TG to end-user consumers. Active sales to any resellers of whatever kind in territories, which TG has exclusively reserved for itself or for third party dealers, are prohibited. TG will inform Customer respectively. Passive sales are exempted from the above restriction. Provisions in the selective distribution network remain unaffected by this Clause 3.1.

3.2. Customer acknowledges its obligation to maintain and promote the extremely high standard of the Products reputation as comprising some of the world's finest glassware, the goodwill symbolized by the "Riedel", "Spiegelau" and "Nachtmann" brands (the "Brands"), and the associated trademarks (the "Trademarks") and trade dress and Products, and to further refrain from any conduct that could be viewed as having a negative impact on the image of the Products, the Brands, the Trademarks, TG, its parents, subsidiaries, and affiliates, such as but not limited to, selling the Products to or via mass merchandisers or discount stores.

3.3. Customer will conduct its activities strictly in accordance with these T&C and all applicable laws and regulations.

4. TERMS OF PAYMENT.

4.1. The payment and delivery terms applicable to Customer are set forth separately in TG's applicable "Payment & Delivery Term Sheets" applicable to Customer (the "Payment & Delivery Terms"), which are hereby expressly incorporated into and form an integral part of these T&C.

4.2. TG may ask for a payment confirmation to be issued by a bank accepted by TG. Payment will be deemed effected as soon as TG is able to freely dispose of the same at its registered office. If payments are effected in freely convertible currencies other than the invoicing currency, the Customer will bear the exchange rate risk. Any bank charges are at Customer's expense. Customer acknowledges its obligation to pay default interest of 11% p.a. as of the due date. Any claims, counterclaims or claims for compensation of Customer shall not entitle Customer to any extension of the period stipulated for payment. TG reserves the right to change its Payment & Delivery Terms or suspend fulfillment of any agreement with Customer if this appears necessary due to Customer's financial situation or payment history.

4.3. An eventually granted cash discount may only be deducted if all outstanding invoices have been fully paid by Customer.

4.4. TG is not obliged to accept checks or bills of exchange; they will only be credited as payment subject to them actually being honored to the value to which they are at disposal. All costs incurred in connection with acceptance of bills of exchange or checks, in particular discounting charges and interest, will be borne by Customer.

4.5. Each delivery by instalment shall be deemed an independent transaction for billing and payment purposes.

4.6. In the event of default in payment by more than sixty (60) days, TG may suspend all deliveries until the full outstanding amount has been credited to TG's account. Al-

GENERAL TERMS AND CONDITIONS OF CONTRACT OF TIROLER GLASHÜTTE GMBH 2021 ("TG").

though TG may accept new Orders, these will not be processed and/or delivered.

4.7. In addition, in the event of default in payment by more than sixty (60) days, all outstanding accounts receivable, also under bills of exchange, will become due for payment immediately irrespective of their due date. TG shall furthermore be entitled to rescind all current contracts and/or confirmed Orders and/or request damages in lieu of performance, to stop deliveries and/or to make them subject to the provision of security and/or to effect delivery only against cash on delivery. The same applies (i) if Customer's company is sold in whole or in part or (ii) if the legal form of Customer's company is changed, (iii) if Customer's financial situation materially changes or deteriorates or (iv) if TG obtains knowledge of facts only after the Order was confirmed, which, upon reasonable consideration, make the granting of credit appear risky. In all of these cases, TG may retain title as described under Clause 12. and may ascertain and collect the Products from its deliveries that are still available from Customer for this purpose, which will not lead to a rescission of contract.

5. PRICES.

Unless otherwise stated in TG's applicable Payment & Delivery Terms or agreed in writing, all prices are stated net per sales unit, EXW Tiroler Glashütte (INCOTERMS 2010) excluding the packaging for shipment. TG issues its invoices in Euros or – at TG's sole discretion – in another currency depending on the Customer delivery address, with the prices applicable at the time of delivery being legally effective. Prices are exclusive of statutory VAT and other taxes, fees or duties. If VAT is payable, it will be stated separately in TG's invoice.

6. DELIVERY AND PASSING OF RISK.

6.1. Unless otherwise stated in TG's applicable Payment & Delivery Terms or agreed in writing, all deliveries will be effected EX WORKS ("EXW", Incoterms 2010) at the relevant warehouse as specified by TG. If the warehouse was not specified by TG, the relevant warehouse is located in Kobernausserwaldstraße 25, A-5212 Schneegattern, Austria.

6.2. Unless otherwise defined in the applicable Payment & Delivery Terms, if so requested by Customer and agreed in writing by TG, Products can be shipped to a different destination. Save where otherwise agreed, TG is entitled to determine the kind of shipment (in particular the forwarding agency, shipment route, packaging). Products will be shipped at Customer's sole cost and risk.

6.3. If Products are shipped to a different destination upon Customer's request, the risk shall pass to Customer on the Products' surrender to the person designated to carry out shipment. Customer shall assume all risk to Products during transportation thereof, TG shall not be obligated to replace or credit Customer for Products that are stolen, lost, broken, damaged, or otherwise altered during or as a result of their transportation, and Customer shall be solely responsible for filing any and all claims for loss or damage with the responsible entity or entities.

6.4. Deliveries will be made by TG according to its operational capabilities. The communicated lead-times of Products are for information purposes only, and the communicated delivery times are not binding; delivery times for Special Orders and Limited Editions will be communicated to Customer on a case-by-case basis and are not binding. Any claims for damages due to non-performance or delayed performance are excluded, and Customer waives any and all claims against TG, its parents, subsidiaries, or affiliates for damages and other liabilities arising from or due to TG's actual or alleged non-performance or delayed performance.

6.5. TG will not be responsible for any delay or failure to perform its obligations under these T&C or otherwise, which arises out of or is due to unforeseeable events or events independent of the intention of the parties, such as events of force majeure ("Force Majeure Event"), including, by way of example and not of limitation, all events of pandemics, epidemics, war, terrorist actions, interventions and prohibitions of official authorities, delays in transport and customs clearance, transport damage, inclement weather, lack of energy, financial crises, labor conflicts as well as delays in delivery on the part of suppliers for any reasons. Delivery times will be prolonged where any event mentioned above occurs. The agreed payment terms are not changed thereby.

6.6. Retail Products are shipped in brown master packs (order units). The master pack is only to protect the retail Products and is not designed to be used as shippable outer carton and may not be used as such. Any other use of the master pack, in particular its use for shipping, is the sole responsibility and risk of Customer.

6.7. Customized packaging is subject to a separate Packaging Agreement.

6.8. Regarding Special Orders, TG reserves the right to supply the quantity deviations of +/- 5% of the quantity ordered (the "Permitted Deviation"), which is customary within the industry. Provided that TG's fulfillment of any Special Order is within the Permitted Deviation, the quantity actually delivered shall be paid for by Customer in full.

6.9. If Products are to be picked up by Customer at a TG warehouse, Customer shall pick up the Products comprising such Order within 10 business days after having

receipt of notice from TG that Products comprising such Order have been made available for Customer's pick up. If Customer fails to pick up such Products within this 10 day window, TG is entitled to charge warehousing fees.

7. PARTIAL DELIVERY.

In case where an ordered Product is out of stock, TG will automatically place the Product on back order, and send the stock as soon as it becomes available. Deliveries by instalments (i.e. partial deliveries) shall be permitted and may be invoiced. If TG delivers any of the Products by instalments, and any one of those instalments contains defective Products for any reason as defined in Clause 8., this shall not entitle Customer to the repudiation of the overall contract of sale entered into under these T&C.

8. DEFECTS.

8.1. All claims, including defect claims and breakage claims, must be made in writing within **twenty-eight (28) days** from the date of delivery of the Products and in any event prior to their use or re-sale, including a detailed description and photos of the defect or the non-compliance; otherwise, the Products are deemed accepted by Customer. Customer shall assume all risk to Products during transportation thereof, TG shall not be obligated to replace or credit Customer for Products that are stolen, lost, broken, damaged, or otherwise altered during or as a result of their transportation, and Customer shall be solely responsible for filing any and all claims for loss or damage with the responsible entity or entities. Defects caused as result of a Force Majeure Event shall be excluded from TG's warranty.

8.2. "Nachtmann" and "Spiegelau" and "Riedel" glasses sold by TG are dishwasher-proof according to DIN EN 12875-1:2005. For glass clouding a warranty of 2 (two) years as of the respective production date (bottom stamp) is granted. No warranty is provided for mechanical damages to the surface.

8.3. Customer acknowledges that deviations may occur between Products from the same series for technical reasons and because of the materials used in the course of the production of glass products, in particular with respect to size, weight, ovality, or the vertical axis according to the relevant technical drawings, which cannot be influenced by TG. Such deviations between Products, in particular compared to earlier deliveries of the same Product, therefore do not constitute a defect.

8.4. In the event of a justified claim by Customer, TG will, at its sole discretion, either replace the defective, broken or damaged Products or issue a credit note, but not both. If TG chooses to replace defective Products, Customer is required to return the defective Products at Customer's cost and risk to TG. Any and all other warranty claims of Customer are excluded.

8.5. The rights relating to defects do not apply in case a defect arises because Customer fails to observe TG's or a TG manufacturer's Product or Product packaging instructions or recommendations, in particular instructions for processing or use of the Product, or generally accepted Product use practices.

9. LIMITATIONS OF LIABILITY.

9.1. Where liability for damages is subject to fault, TG's liability for damages – irrespective of the legal grounds – shall in each case be limited in accordance with this Clause 9.

9.2. TG shall not be liable if and to the extent that Product instructions and/or recommendations, in particular instructions for processing and use of the Products and/or the Product packaging, and/or generally accepted Product use practices are not observed by Customer, unless Customer furnishes proof that the damage would have occurred even if the Product or Product packaging instructions and recommendations had been observed. Further, TG shall not be liable for any damage or loss resulting from the purchase, handling, storage, packing, labelling, distribution, promotion, use or sale of the Products by Customer.

9.3. TG shall only be liable for damage to the extent that the damage was caused by TG by gross negligence or willful intent. Liability for slight negligence is excluded, except in the case of personal injury. In such cases, however, TG's liability shall be limited to the foreseeable and typical damage.

9.4. The burden of proof lies with Customer.

9.5. In all other respects, TG's liability is excluded and shall in no event include any incidental, indirect or consequential damages of any kind.

9.6. Decorations of any kind not been made or commissioned by TG, such as engravings, silk-screenings etc., are the sole responsibility and risk of Customer. TG will not be responsible and shall be excluded from any warranty whatsoever, especially but not limited to that heavy metals or other dangerous materials are applied, or if the material used is not water-resistant or dishwasher-proof. Customer shall indemnify and hold TG harmless from any and all claims, suits, losses, damages, demands, injuries and expenses (including reasonable attorney's fees) arising out of or related to any claims made against TG based on any decorations (such as engraving, silk-screening, etc.) made to the Products by Customer.

GENERAL TERMS AND CONDITIONS OF CONTRACT OF TIROLER GLASHÜTTE GMBH 2021 ("TG").

10. RETURNS.

Unless due to their defectiveness Products are returned in accordance with Clause 8, all returns are subject to TG's prior written approval and subject to the exceptions set out in these T&C. Special Orders, Limited Editions or Products that have Authorized Packaging Changes or are engraved, decorated or personalized in any other way cannot be returned. Returned Products must be part of the current collections of TG and in mint, resalable condition, packed in the original undamaged boxes and in the original sealed master packs. Returns must be shipped within thirty (30) days after having received TG's written prior approval and shall be delivered to TG's warehouse Schneegattern, Austria, freight, risk and costs at Customer's expense and responsibility. For Products returned in accordance with these provisions and such Products not being defective under Clause 8, the EXW Tiroler Glashütte Product net price valid at the date of the purchase will be credited minus a 15% restocking and handling fee. Any returns not in conformity with the foregoing may be refused by TG.

11. INTELLECTUAL PROPERTY RIGHTS.

11.1. TG or TG's licensors hold any and all rights, titles, good-will, and interest of any nature whatsoever, including but not limited to any and all intellectual property rights, in particular copyrights, trademarks, trade secrets, design patent, patent rights and/or design rights, relating to the Products, the Product designs, the glassware samples and the glassware sample designs and prototypes, including, but not limited to, the respective drawings, tools, shapes and molds.

11.2. Any and all tools, molds, drawings, plans and prototypes provided to a Customer are the sole property of TG, including but not limited to any and all intellectual property, even if Customer bears the costs of their acquisition in part or in full, and will not be handed over at the end of any kind of cooperation or contract.

11.3. Customer is entitled to the restricted use of the Brands and/or Trademarks affixed to the Products or their packaging in its unchanged and originally packed form, in order to identify the Products. By doing so, Customer does not acquire any rights or licenses to the Brands or the Trademarks, or any other proprietary material of TG or its licensors. Customer undertakes to refrain from any other use.

11.4. Any use of the Brands, the Trademarks or of any other intellectual property of TG or of TG's licensors, as well as photos or videos thereof, in publications, electronic (internet) advertising, social media pages, or printed matter is only permitted upon prior written authorization of TG. In addition, Customer undertakes not to use any marks or signs that are likely to be confused with those of TG or of TG's licensors, or with "Riedel", "Spiegelau" or "Nachtmann" or similar marks or signs or to have them protected in whatever form, in any jurisdiction.

11.5. Any and all materials and related documentation TG provides to Customer hereunder or through any contract together with any and all rights, titles and interests in the intellectual property, including but not limited to the Brands, the Trademarks, or any other proprietary material of TG and its licensors as well as all goodwill and copyright, in and arising from the Brands and the Products, vested therein or related thereto, remain the sole and exclusive property of TG or its licensors. Documents such as catalogues, brochures, illustrations, photos, videos, and the like as well as samples and designs remain at all times the intellectual property of TG or TG's licensors, protec-

ted by the relevant statutory provisions regarding reproduction, imitation, competition, etc. Customer undertakes not to make such material and documents available to third parties, either in whole or in part, without TG's prior written authorization or to use them for any purpose apart from the purpose for which they were handed over to Customer. In case an authorization is granted that allows Customer to make such material and documents available to third parties, Customer shall be obliged to impose all obligations arising out of these T&Cs upon such third party. Customer remains liable to TG for any acts or omissions of such third party, and Customer shall hold TG harmless from any and all claims and expenses (including reasonable attorney's fees) arising out of or related to any such acts or omissions. If no Order is placed and/or upon the request of TG, Customer must return all materials and documents.

11.6. Any use of the Brands or of any intellectual property rights of TG or of TG's licensors on social media platforms such as Facebook, Twitter, Instagram etc. or any setting up of a "Riedel", "Spiegelau" or "Nachtmann" account on such social media platforms shall only be permitted upon prior written consent of TG.

12. RETENTION OF TITLE.

12.1. TG shall retain title to the Products and samples delivered until full payment is received for such Products by TG.

12.2. However, Customer is entitled to resell the Products in ordinary business in the usual way customary in the trade. If Products, which have not been paid for yet are sold, Customer shall assign the claim thus arising vis-à-vis third parties to TG. TG shall be entitled to disclose the assignment. Customer shall immediately make available to TG all information required in order to pursue all claims and agrees to comply with all formalities that may be necessary for a valid assignment.

12.3. Customer is not entitled to pledge or hand over Products of TG that have not been paid for as security. Customer is obliged to claim the title of TG to the Products in relation to third parties and to notify TG immediately in writing if third parties assert claims with respect to the Products or if execution is initiated.

13. SEVERABILITY.

If any provision of these T&C is deemed ineffective or adjudicated to be invalid by a competent authority, the validity of the remaining provisions shall not be affected. The Parties shall agree on a new effective provision which comes as close as possible to the commercial purpose of the ineffective provision without delay.

14. APPLICABLE LAW, PLACE OF JURISDICTION.

14.1. The T&Cs and the contract concluded with Customer including its pre- and post-contractual phases and effects are subject to, and shall be interpreted in accordance with, **Austrian law**. Applicability of UN Sales Law (CISG - United Nations Convention on Contracts of the International Sale of Products) is excluded.

14.2. The exclusive jurisdiction of Kufstein District Court, Austria, or Innsbruck High Court, Austria, (depending on jurisdiction over subject) is agreed for any disputes arising out of the contract concluded with Customer or the T&Cs underlying the contract, including the pre- and post-contractual phases and effects. However, TG is free to sue at Customer's registered office.

**AUSTRIA****Tiroler Glashütte GmbH**

Weissachstrasse 28-34
6330 Kufstein, Austria
Phone: +43 (0) 5372 64896
Fax: +43 (0) 5372 63225
Email: info@riedel.com

**JAPAN****RSN Japan Co. Ltd**

Aoyama Twin Tower (West) 2 F
1-1-1 Minami-Aoyama
Minato-Ku, Tokyo 107-0062, Japan
Phone: +81 3 4530 6900
Fax: +81 3 5775 5889
Email: info@riedel.co.jp
www.riedel.co.jp

**AUSTRALIA****RSN Australia Pty Ltd**

201/32 Walker Street
North Sydney NSW 2060, Australia
Phone: +61 2 9966 0033
Fax: +61 2 9906 7802
Email: info@rsnaustralia.com.au

**NEW ZEALAND****RSN New Zealand Pty Limited**

PO Box 99841
Newmarket 1149 Auckland, NZ
Phone: +612 99 66 00 33
Email: info@rsn.co.nz

**CANADA****Crystal of Canada, Inc.**

110 Fieldcrest Avenue
Raritan Plaza 1, 4th Floor
Edison, NJ 08837, USA
Phone: +1 888 4-RIEDEL
Fax: +1 732 346 8977
Email: info@riedelcanada.com

**SWITZERLAND****RSN-Switzerland GmbH**

c/o KD Zug Fiduciary Ltd.
Untermüli 7, Postfach 7444
6302 Zug, Switzerland
Phone: +41 41 766 26 35
Email: webshopsui@riedel.com

**CHINA****RSN Crystal Trading (Shanghai) Ltd.**

RM2301-2302 Citic Plaza
859 Sichuan Road North
Shanghai 200080, China
Phone: +86 21 60707358
Email: info.asia@riedel.com

**UNITED KINGDOM****RSN.UK Ltd t/a Riedel**

Lakeside House
3 Trentham Office Village
Trentham Lakes South
Stoke on Trent, ST4 8GH
United Kingdom
Phone: +44 (0) 1782 646 105
Fax: + 44 (0) 1782 646 106
Email: info@riedel.co.uk

**FRANCE****RSN Crystal France**

22 rue Hector Malot
75012 Paris
Phone: +33 1 42 89 86 08
Email: riedelfrance@riedel.com

**USA****Crystal of America, Inc.**

110 Fieldcrest Avenue
Raritan Plaza 1, 4th Floor
Edison, NJ 08837, USA
Phone: +1 732 346 8960
Fax: +1 732 346 8977
Email: info@riedelusa.com

**GERMANY****RSN Deutschland GmbH Vertrieb**

Zacharias-Frank-Straße 7
D-92660 Neustadt a.d. Waldnaab
Phone: +49 (0) 9602 30-0
Fax: +49 (0) 9602 30-1100
Email: info@riedel.com

